

EZ UP[®]

PNEUMATIC LIFT TABLE

Bishamon[®]



The Bishamon EZ-UP is the ideal lifting and work positioning solution whenever operator control is required and shop air is convenient. Incorporating many of the same advanced ergonomic features as the popular EZ Loader (captive air pallet positioners), the EZ-UP utilizes constant shop air, allowing the operator to conveniently position the load for loading or unloading. The integral rotator ring eliminates the need to reach, stretch or walk around the pallet, making the EZ-UP an unsurpassed ergonomic tool that will help increase productivity at your facility. Pneumatic lifts contain no electrical or hydraulic components. They require little maintenance and provide the ideal tool where cleanliness is a must and where sparks can be hazardous.

Lift tables in general position the work closer to the worker, which reduces the risk of injury, worker fatigue, or the chance of damage to sensitive products that are work in process. Typical applications are found in most any manufacturing facility (common in the automotive industry) processing and distribution. The EZ-UP is also ideal in clean rooms, paint stations and food processing / packaging applications.

Bishamon

Bishamon Industries Corporation

5651 East Francis Street
Ontario, California 91761-3601

(909) 390-0055 • (800) 358-8833
Fax (909) 390-0060

www.bishamon.com

Warranty - Bishamon Industries Corp. ("Bishamon") warrants its products to be free from defects in material and workmanship for a period of one (1) year from the date of initial shipment. This warranty shall not apply to any misuse, mishandling, accident, shipping, alteration, or unauthorized repair of any Bishamon product or part. For complete details of warranty, please contact Bishamon at 800-358-8833.

EZ UP®

EZU & EZU-R PNEUMATIC LIFT TABLES

Working Harder To
Make Your Life Easier

EZ UP Model EZU-15

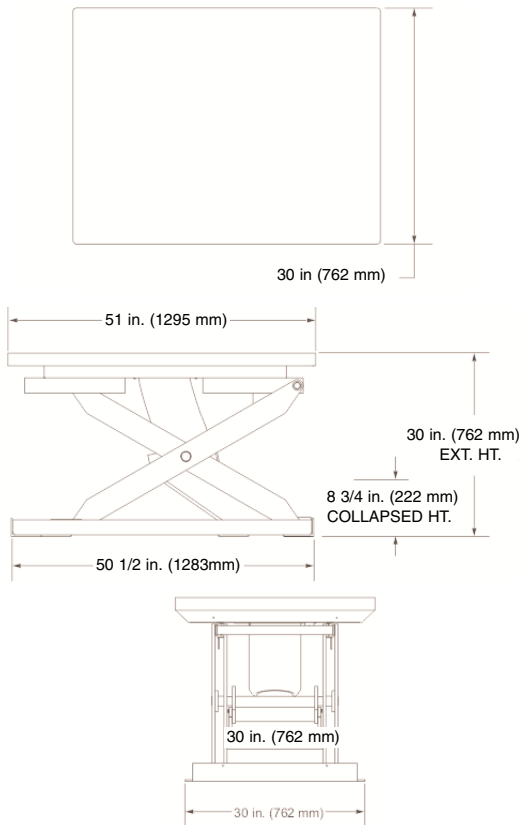

EZ UP Model EZU-15-R

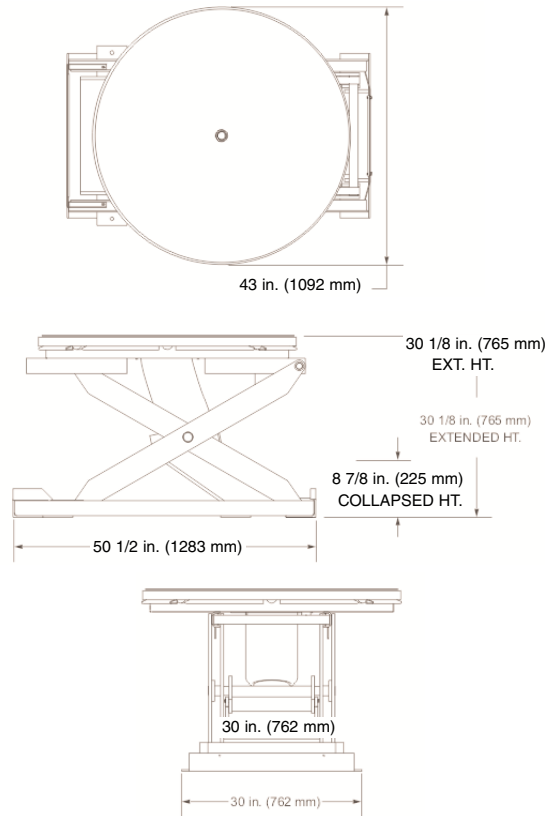

Selector Table for EZU Series Pallet Positioners

Model	Travel (inches)	Capacity* @ 80 p.s.i.	Height (Inches)		Standard Platform Size (inches)	Ship Weight
			Lowered	Raised		
EZU-15	21.25	1500 lbs.	8.75	30.00	30 x 51	450 lbs.
EZU-15-R	21.25	1500 lbs.	8.88	30.13	43" Diameter	495 lbs.

* Capacity increases to 2,000 lb. @ 90 p.s.i. Note: Not recommended for applications requiring exact positioning of work loads.



Model EZU-15



EZU-15-R

With Optional 48" x 48" Rotating Top and Valve Stand

Standard Features

- Firestone Airstroke Actuator raises and lowers the table platform to vertically position the load to the desired height
- Durable and attractive polyester powder coating adds life and superior corrosion resistance to the finish
- Heavy-duty structural steel construction with rugged base frame
- Entrapped rollers on base and platform for added stability
- Dual attached maintenance blocks
- Rotating models feature a secured center pivot with ball bearing that provides smooth, even rotation
- High quality brass hand lever controls allows easy operation
- Clean design with minimum of maintenance needed
- Fork truck transportable without the need for additional options

Optional Accessories

- Rotator Ring Brake
- Accordion Bellows Skirting
- Semi-Live Portability
- Oversize Platform (Non-Rotating) up to 48" x 64" For Surface Mounting Only
- Rotating Platform - Solid Rectangular (44x44/44x46/44x48/46x46/46x48/48x48)
- Hand Control Valve Stand
- Stainless Steel Model



Bishamon®

Bishamon Industries Corporation

5651 East Francis Street
Ontario, California 91761-3601
(909) 390-0055 • (800) 358-8833
Fax (909) 390-0060

www.bishamon.com

DISTRIBUTED BY:

