

EZ LOADER[®]

BY BISHAMON

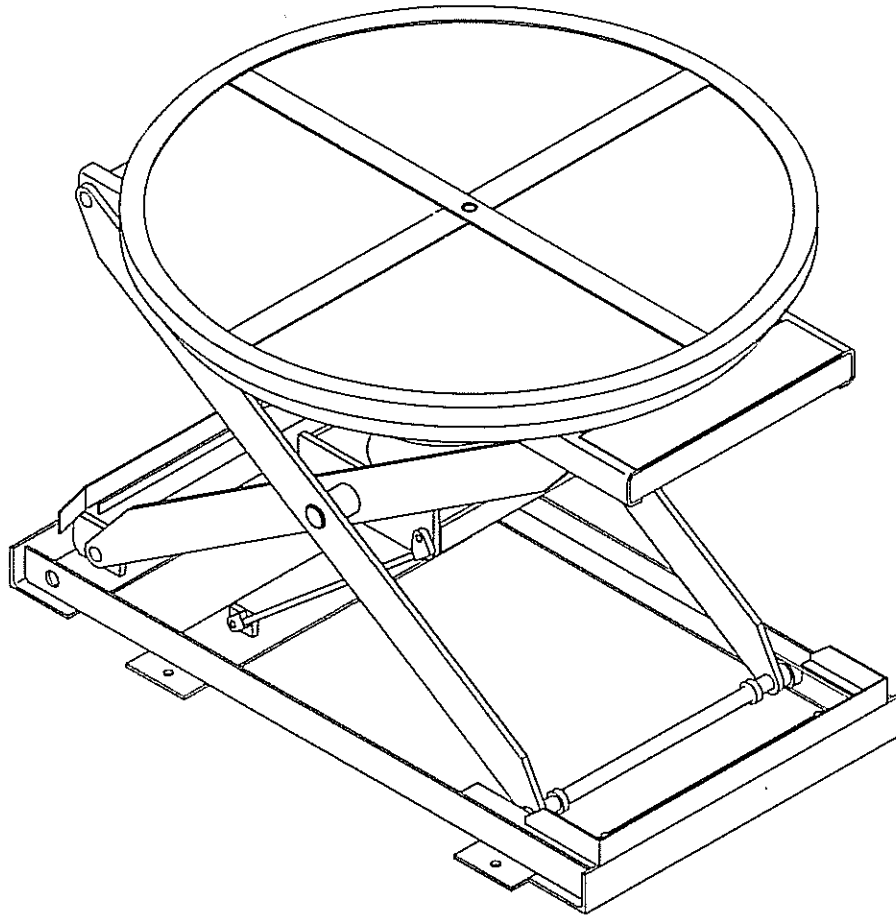

Models EZ-30 & EZ-45

Service **Manual**

BISHAMON INDUSTRIES CORPORATION
5651 East Francis Street
Ontario, California 91761, USA
(909) 390-0055 (800) 231-3187

United States Patent
European Patent

5299906
0512775

USA
United Kingdom
France
Germany

Other Patents Pending

EZCER2



Table of Contents

Contents

Page

Getting Started	1
Inspection	1
General Warnings and Cautions	1
Safety Warning Label Locations	2
Specifications	3
Recommended Floor Area	4
Functional Description	5
Scissor Blocking Instructions	6
Installation	7
Installation Instructions	7
Quick Set-up	8
Set-up Procedure	8
Operating Instructions	11
Handling Instructions	12
Routine Maintenance	12
Replacement Parts	13
Optional Equipment	16
Portability Instructions	18

List of Figures

Figure 1 - Safety Warning Label Locations	2
Figure 2 - Specifications Drawings	3
Figure 3 - Recommended Floor Area	4
Figure 4 - Functional Description	5
Figure 5 - Maintenance Bar Operation	6
Figure 6 - EZ Loader Pneumatic Components	7
Figure 7 - Handling the EZ Loader	8
Figure 8 - EZ-30 Height vs. Load Diagram	9
Figure 9 - EZ-45 Height vs. Load Diagram	9
Figure 10 - Height vs. Weight Example	10
Figure 11 - Fitting Disassembly	12
Figure 12 - EZ Loader Pneumatic Schematic	13
Figure 13 - EZ-30 & EZ-45 Exploded View	14
Figure 14 - Bellows Illustration	16
Figure 15 - Brake Parts Illustration	17
Figure 16 - Portability Illustration	17
Figure 17 - Portability Description	18
Figure 18 - Portability Wheel Engagement	19
Figure 19 - Portability Wheel Disengagement	19

Date Placed in Service _____

Serial Number _____

Dealer _____

GETTING STARTED

PLEASE READ THIS MANUAL CAREFULLY BEFORE USING THE EZ LOADER. The safety of all persons installing, using or servicing the EZ Loader is of utmost importance to Bishamon. The EZ Loader is capable of supporting heavy loads and is capable of causing SEVERE PERSONAL INJURY if used improperly or if certain safety precautions are not taken. When properly used and maintained, the EZ Loader will provide many years of safe, trouble free service. If you have any questions about any of the instructions in this manual or about the use of this product, PLEASE contact your DEALER or Bishamon Industries Corporation.

INSPECTION

IMMEDIATELY upon receipt of the EZ Loader, remove all packing and strapping material and visually inspect the unit for damage. Any damage to the unit MUST BE NOTED on the delivery receipt. After the preliminary inspection is conducted, the unit should be thoroughly inspected for any concealed damage that was not readily apparent during the preliminary inspection. Any concealed damage found that was not noted on the delivery receipt should be IMMEDIATELY reported in writing TO THE DELIVERING CARRIER.

SAFETY DEFINITIONS

Bishamon uses the following system to identify the degree of risk associated with hazards and unsafe practices.

WARNING - Hazard or unsafe practice which, if not avoided, could result in **DEATH** or **SEVERE PERSONAL INJURY** and **PROPERTY DAMAGE**.

CAUTION - Hazard or unsafe practice which, if not avoided, may result in **MINOR** or **MODERATE PERSONAL INJURY** and **PROPERTY DAMAGE**.

GENERAL WARNINGS



1. **READ THIS MANUAL COMPLETELY BEFORE USING AND THOROUGHLY UNDERSTAND AND FOLLOW ALL SAFETY INSTRUCTIONS.**
2. The EZ Loader is designed for use with stable, uniformly distributed loads on a solid level floor. **DO NOT** concentrate the load at one point on the pallet or platform. **ALWAYS** uniformly distribute each layer of load over the supporting surface. **DO NOT** use the EZ Loader for any purpose other than its intended use.
3. **SHEARING HAZARD. ALWAYS** keep hands and feet clear of the scissor mechanism and all moving components. **DO NOT** put hands under the platform when in use. **SEVERE PERSONAL INJURY** could result.
4. **CRUSHING HAZARD. ALWAYS** keep hands and feet clear of all moving components. **DO NOT** put feet on the base frame when in use. **SEVERE PERSONAL INJURY** could result.
5. **PINCH POINT HAZARD. ALWAYS** keep hands and fingers clear of the underside of the rotator ring. **SEVERE PERSONAL INJURY** could result.
6. **NEVER** sit, stand or ride on the platform or rotating surface. Moving components could cause loss of balance. **SEVERE PERSONAL INJURY** could result.
7. **NEVER** go under the platform until the load is removed and the scissor mechanism is blocked. **SEVERE PERSONAL INJURY** could result.
8. **NEVER** place any load on the EZ Loader with the scissor mechanism blocked. **SEVERE PERSONAL INJURY** and **PROPERTY DAMAGE** could result.

9. **DO NOT** overpressurize or overload the EZ Loader. **ALWAYS** stay within the designated pressure and capacity ratings. **SEVERE PERSONAL INJURY** and **PROPERTY DAMAGE** could result.
10. When removing a loaded pallet, **ALWAYS** raise the load until the bottom of the pallet clears the top of the EZ Loader before backing up. **ALWAYS** stay well clear of the load while it is being removed from the EZ Loader. **SEVERE PERSONAL INJURY** and **PROPERTY DAMAGE** could result.
11. **ALWAYS** ensure all safety warning labels are in place and legible. If not, remove the EZ Loader from service and replace the required labels. Refer to Figure 1 for label descriptions and locations.
12. **DO NOT** inflate the air spring when removed from the EZ Loader. Pressurizing the unrestricted air spring may cause assembly to burst. **SEVERE PERSONAL INJURY** and **PROPERTY DAMAGE** could result.

! CAUTION

1. **ALWAYS** use clean dry air to pressurize the system.
2. **ALWAYS** securely anchor the EZ Loader base frame to floor to ensure maximum stability.
3. The optional Semi-Live Portability is designed for use with an unloaded EZ Loader. **ALWAYS** remove the load before engaging the portability wheels. **NEVER** apply load with the portability wheels engaged.

SAFETY WARNING LABEL LOCATIONS

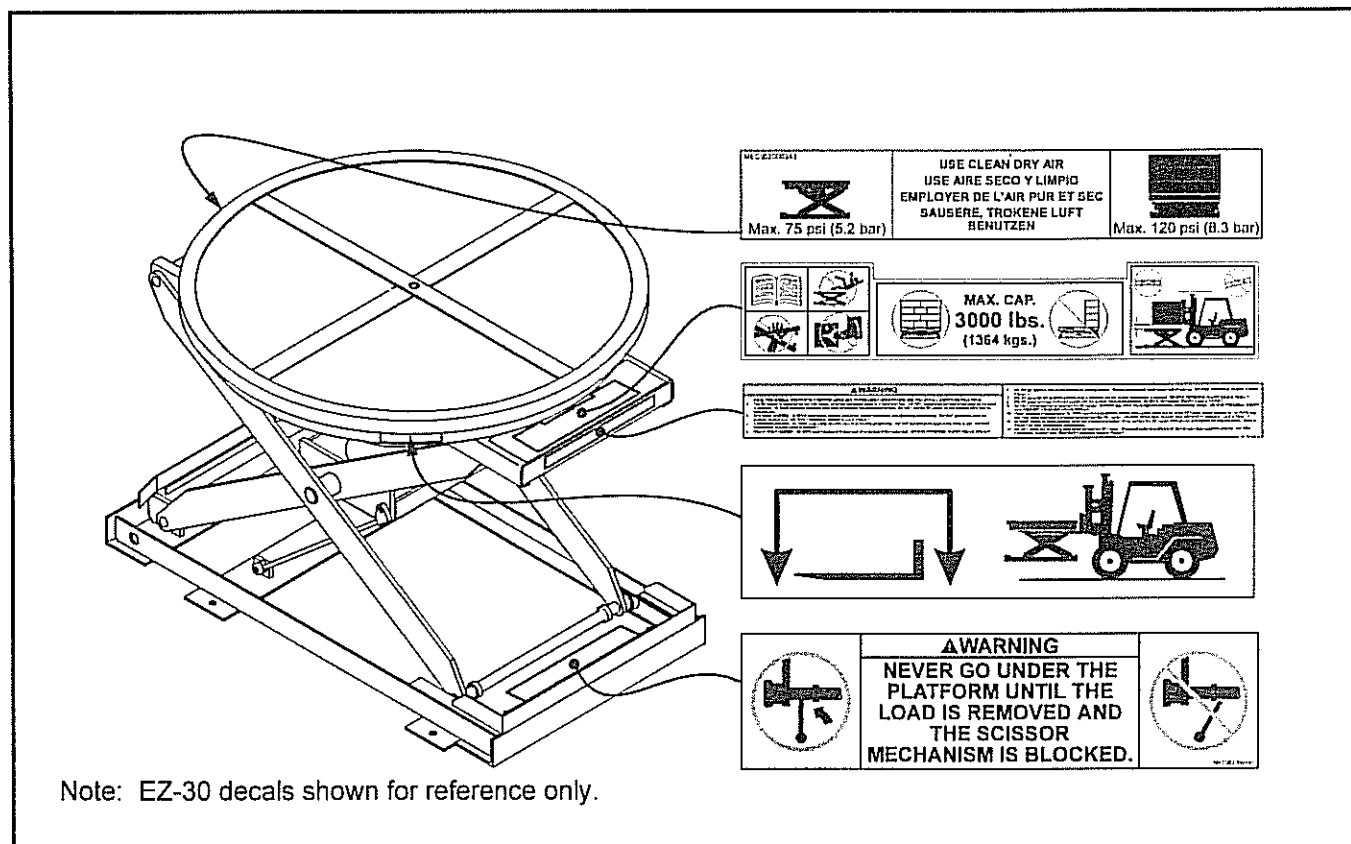

Figure 1 Safety Warning Label Locations

SPECIFICATIONS AND SPECIFICATION DRAWING

SPECIFICATIONS:

EZ-30 & EZ-45

1. MAXIMUM CAPACITY- EZ-30 3000 lbs. (1364 kgs.)
EZ-45 4500 lbs. (2045 kgs.)
2. MINIMUM CAPACITY* - EZ-30 450 lbs. (205 kgs.)
EZ-45 1100 lbs. (500 kgs.)
3. EXTENDED HEIGHT - 30 in. (762 mm)
4. COLLAPSED HEIGHT - 8.75 in. (222.5 mm)
5. WEIGHT - EZ-30 350 lbs. (159 kgs.)
EZ-45 375 lbs. (171 kgs.)
6. AIR REQUIREMENTS - 75 psi. (5.2 Bar) Dry Shop Air
7. MAXIMUM INTERNAL AIR PRESSURE - 120 psi. (8.3 Bar)
8. RELIEF VALVE SETTING - 135 psi. (9.3 Bar)
9. AIR SPRING - Two Ply Fabric Reinforced Rubber.
10. SOUND PRESSURE LEVEL - <70 dB(a)
11. OPERATING ENVIRONMENT - Indoors.
12. LIGHTING REQUIREMENT - Good General Lighting
13. OPERATING ENVIRONMENT TEMPERATURE - +30 to +120°F.
(-1.1°C to 48.9°C)

*At collapsed capacities less than 450 lbs. (205 kgs.) for the EZ-30 and 1100 lbs. (500 kgs.) for the EZ-45, the internal volume of air is not capable of extending the platform to the maximum extended height.

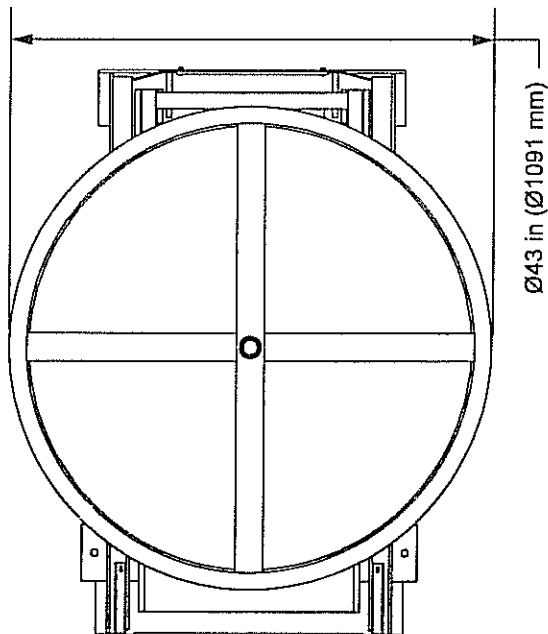
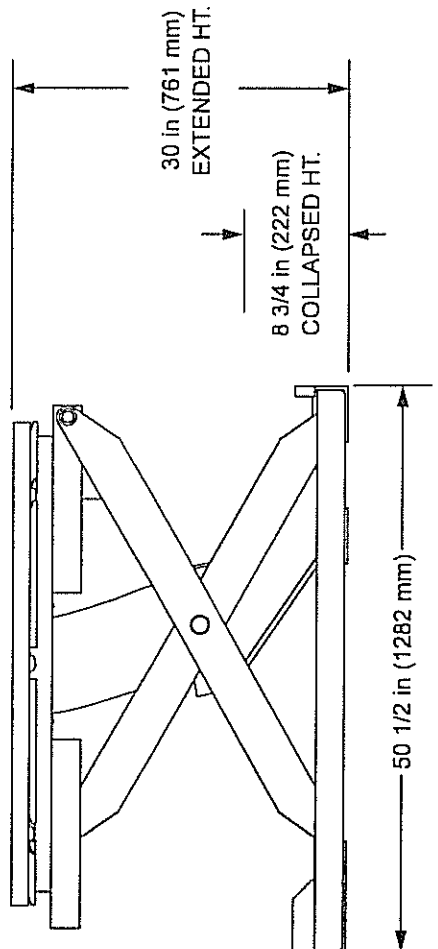
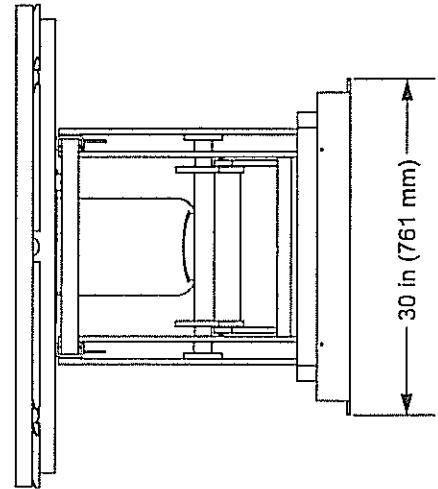

Figure 2 Specification Drawing

RECOMMENDED FLOOR AREA

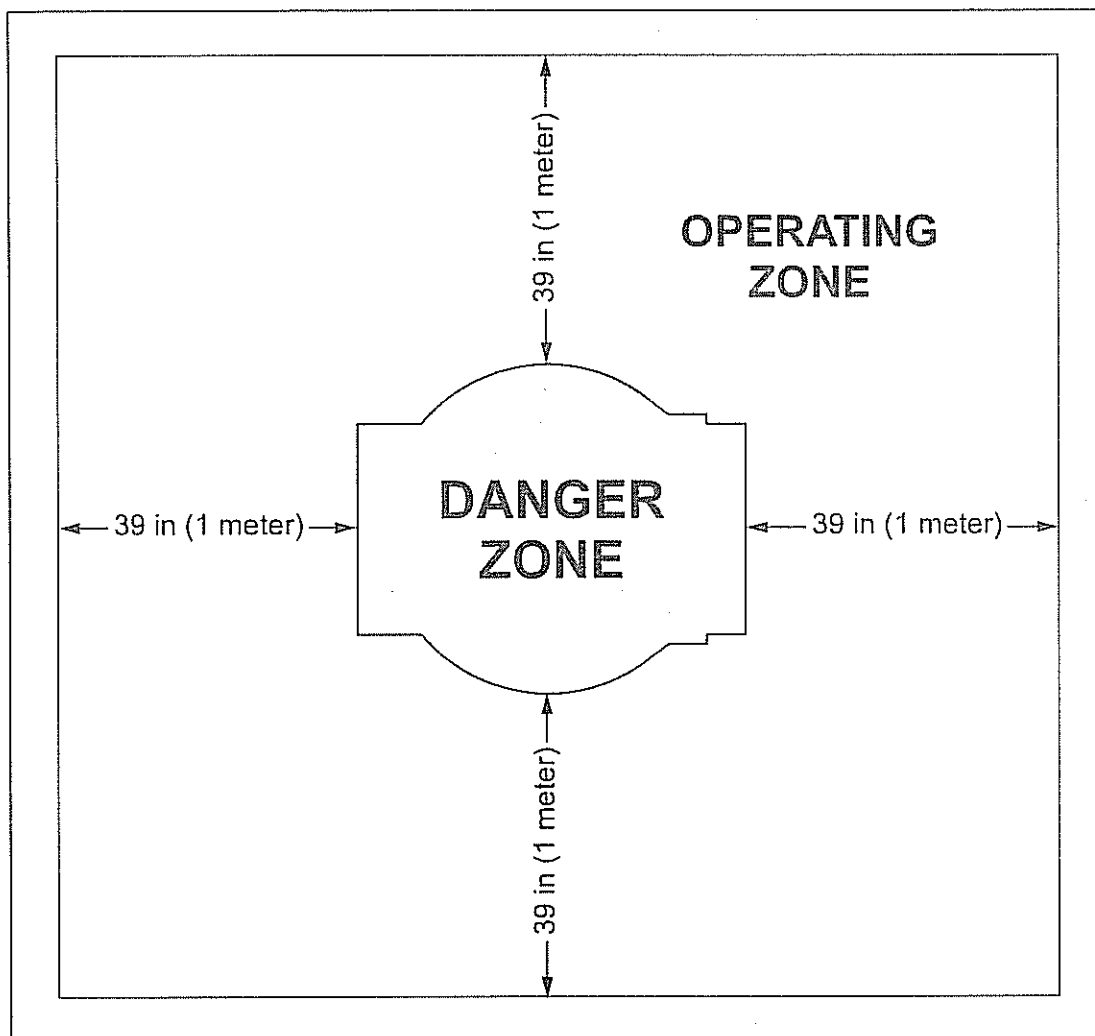

Figure 3 Recommended Floor Area

The EZ Loader's recommended floor area, shown in Figure 3, identifies the "Danger Zone" and the "Operating Zone". The Danger Zone is the area inside the base frame and under the platform structure. The recommended Operating Zone is a distance of 39 inches (1 meter) extending beyond the danger zone on all sides.

FUNCTIONAL DESCRIPTION

The EZ Loader is a pneumatic load elevator designed to assist the operator when manually loading or unloading a palletized load. As the load weight increases or decreases the EZ Loader gradually lowers or raises to maintain the top of the load at a comfortable working height, eliminating operator strain due to bending and stretching.

The EZ Loader is completely variable in capacity. Load support is provided by a Firestone Airstroke Actuator in a captive air system. Load capacity and height is determined by the initial system pressure. The initial pressure varies from approximately 15 psi (1.0 Bar) to 75 psi (5.2 Bar) for the EZ-30 and from approximately 19 psi (1.3 Bar) to 65 psi (4.5 Bar) for the EZ-45. This corresponds to a collapsed capacity range from approximately 450 lbs (205 kgs) to 2200 lbs (1000 kgs) for the EZ-30 and from approximately 1100 lbs (500 kgs) to 3500 lbs (1591 kgs) for the EZ-45. All additional load above the collapsed capacity is added to the EZ Loader while it is in the collapsed position. Maximum capacity is 3000 lbs (1364 kgs) for the EZ-30 and 4500 lbs (2045 kgs) for the EZ-45.

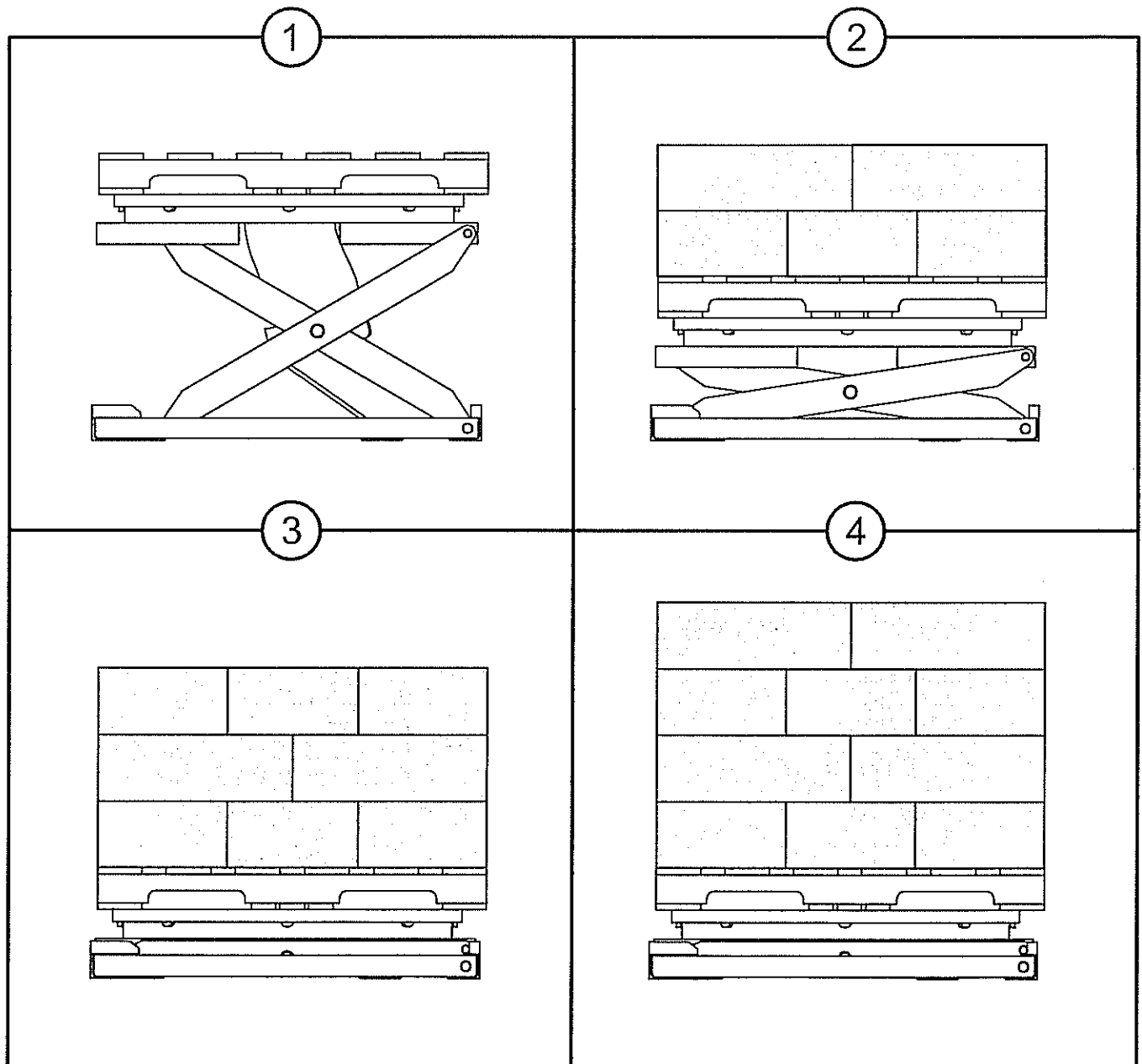

Figure 4 Functional Drawing

SCISSOR BLOCKING INSTRUCTIONS

To Engage The Maintenance Bars

1. Remove all load from the platform and allow the EZ Loader to extend to its fully raised position.
2. As detailed in Figure 5, rotate the maintenance bars approximately 90° so that the bars are parallel with the scissor legs. The end of the bar should be positioned between the end of the leg and the collar on the roller shaft.

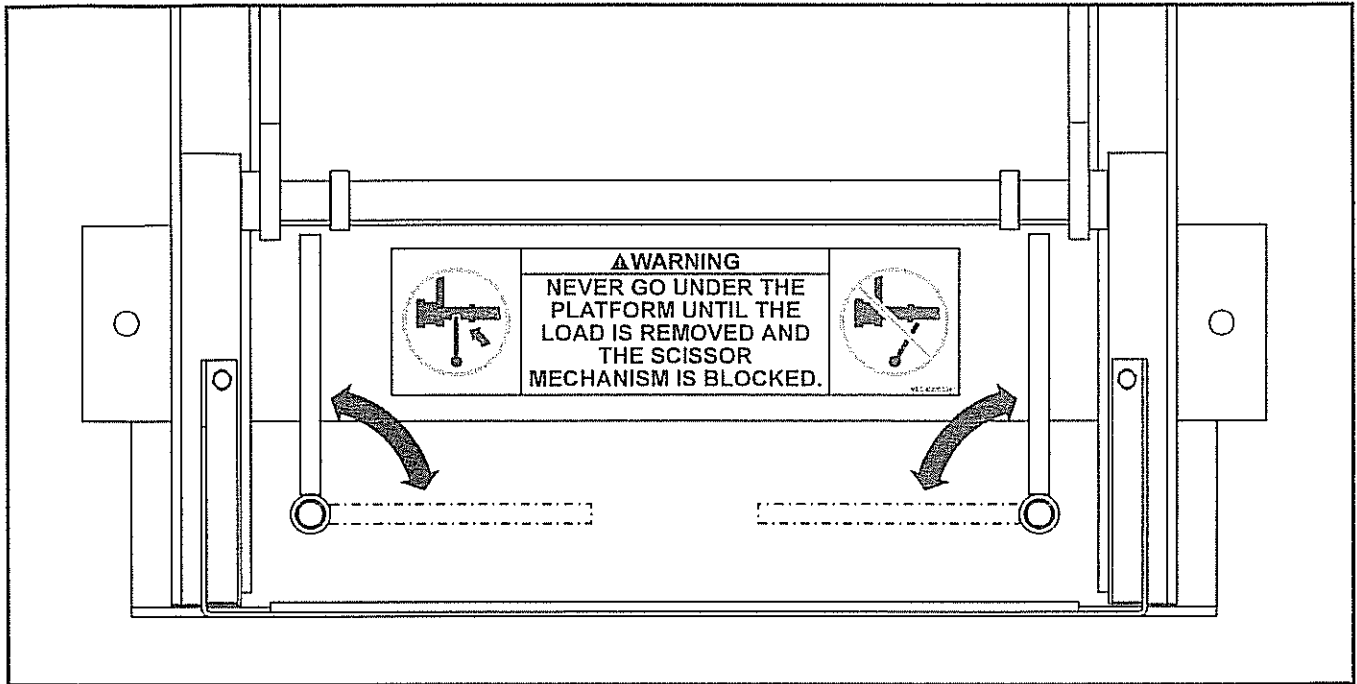

Figure 5 Maintenance Bar Operation

3. Slowly open the purge valve to release air from the system and allow the scissor mechanism to rest against the maintenance bars. ALWAYS check the position of the bars before going under the platform.

To Disengage The Maintenance Bars

4. Repressurize the EZ Loader to the desired initial pressure or until the EZ Loader is fully raised.
5. Rotate the maintenance bars approximately 90° to their original position.

WARNING

NEVER place any load on the EZ Loader with the scissor mechanism blocked. **SEVERE PERSONAL INJURY** and **PROPERTY DAMAGE** could result.

INSTALLATION

Installation of the EZ Loader is a simple process; however, certain precautions must be taken to ensure years of trouble free service. The EZ Loader requires clean, dry, compressed air to operate properly. A filter and regulator with a pressure gauge should be installed on an air line in the installation area before initially charging the system for use.

Before you begin, locate and identify the pneumatic components detailed in Figure 6. These components will be referred to in the Installation and the Set-Up procedures. Make sure you understand the function of each component before proceeding.

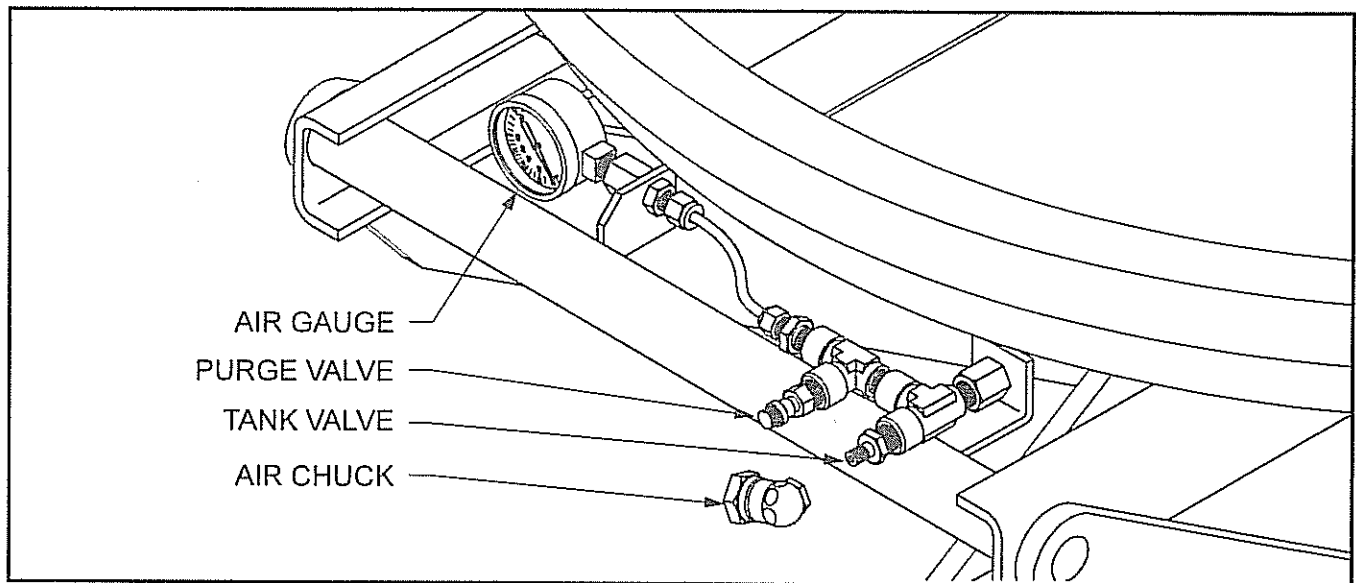

Figure 6 EZ Loader Pneumatic Components

Air Chuck - The air chuck is supplied with the EZ Loader and is used to charge the EZ Loader with air. The air chuck body is supplied with 1/4 inch female pipe threads and must be attached to the end of the air line extending from the filter/regulator.

Air Gauge - The air gauge indicates the EZ Loader's internal system pressure. The yellow band indicates the maximum pressure range for the EZ Loader in the raised position. The red mark indicates the maximum pressure for the EZ Loader in the collapsed position.

Purge Valve - The purge valve is a manual one way valve used to release air from the EZ Loader. Turning the valve counter-clockwise opens the valve and releases air from the system. Turn the valve clockwise to close. The valve should be closed with finger tight pressure. **DO NOT** use a wrench to close the valve, leakage may occur if over-tightened.

Tank Valve - The tank valve is a one way valve used to charge the EZ Loader with air. The end of the tank valve is designed to mate with the air chuck. Pressing the air chuck against the end of the tank valve allows air to enter the system.

INSTALLATION INSTRUCTIONS

1. Make sure the installation area is clean before starting. Check the installation surface to ensure it is relatively smooth and level. Otherwise, the EZ Loader base frame should be shimmed to make it level.
2. Using a fork lift or similar equipment, move the palletized EZ Loader to the location it is to be installed.
3. Remove the steel bands securing the EZ Loader to the pallet. Next, remove all packing material and place it off to the side.

4. Attach the air chuck to the air line extending from the filter/regulator.
5. Set the regulator to 50 psi (3.5 Bar) and initially charge the system by engaging the air chuck to the EZ Loader's tank valve. The air spring will inflate and the EZ Loader will gradually extend to its maximum raised height. If escaping air is detected, close the purge valve (finger tight). Allow the system to completely pressurize and disengage the air line from the EZ Loader.

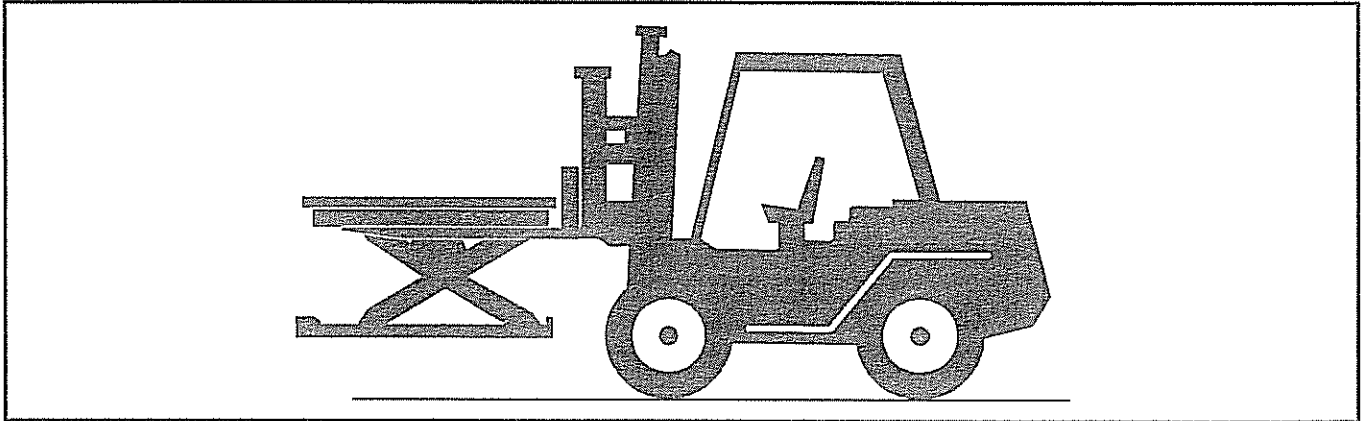

Figure 7 Handling the EZ Loader

6. Using a fork lift, position the forks under the platform structure, as detailed in Figure 7. Lift the EZ Loader off the pallet. Next, remove the pallet and place it off to the side. Position the EZ Loader in the desired location.
Bishamon recommends securing the EZ Loader to the floor for maximum stability. However, in most applications, floor anchors are not required for safe operation. Contact your Dealer or Bishamon Industries Corporation if you have any questions regarding the proper installation of the EZ Loader. Complete steps 7 and 8 to secure the EZ Loader to the floor.
7. The base frame of the EZ Loader has 4 pre-drilled holes for lagging the unit securely to the floor. Using the 4 holes as a template, mark the holes on the floor. Using the fork lift, shift the position of the EZ Loader to allow room for drilling, then drill. When complete, reposition the lift and install anchors, lagging the EZ Loader securely to the floor. NOTE: Make sure the base angles are fully supported along their entire length with shims or concrete grout.
8. The EZ Loader is now ready for operation. Refer to the Set-Up procedure to properly set the initial pressure for the desired capacity.

QUICK SET-UP

The EZ Loader is complete variable in capacity and very easy to set-up. Complete the installation instructions detailed on pages 7 and 8. Pressurize the EZ Loader to its maximum system pressure in the raised position. Place all or any portion of the load on the EZ Loader, then open the purge valve to release air and set the top of the load at the desired working height. Close the purge valve finger tight. For a more detailed explanation refer to the following set-up procedure.

SET-UP PROCEDURE

The load capacity and height of the EZ Loader is determined by the initial system pressure in the raised position. The initial pressure is completely variable and for most applications should be between 15 psi (1.0 Bar) and 75 psi (5.2 Bar) for the EZ-30 and between 19 psi (1.3 Bar) and 65 psi (4.5 Bar) for the EZ-45. An initial pressure less than the minimum stated above can be used; however, the EZ Loader will not extend to its maximum height. Diagrams of the rotator ring height as it relates to the load weight for EZ-30 and for the EZ-45 are shown in Figures 8 and 9 respectively. To demonstrate how the EZ Loader's performance changes as the initial pressure is increased, a total of seven (7) performance curves are presented with each diagram. These curves correspond to various initial pressures for each model. For most applications the EZ Loader should be completely collapsed at approximately 75 percent of the total load (load + pallet weight). The remaining load (usually the last layer) is added to the EZ Loader while it is in the collapsed position. To set-up the EZ Loader for use, complete steps 1-7 on page 10.

HEIGHT vs WEIGHT DIAGRAM

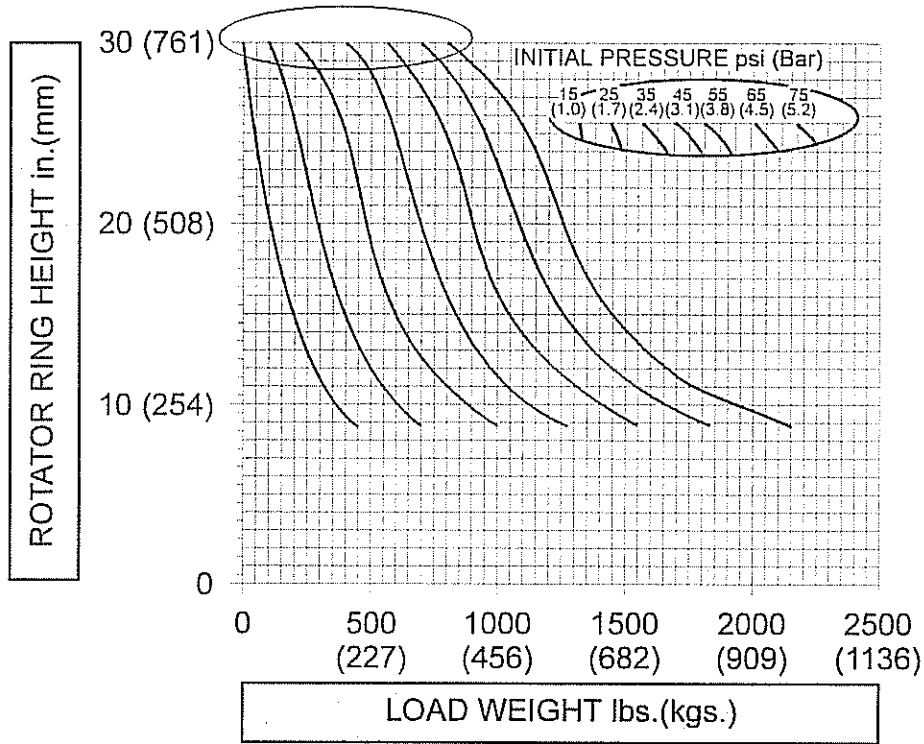

Figure 8 EZ-30 Height vs. Load Diagram

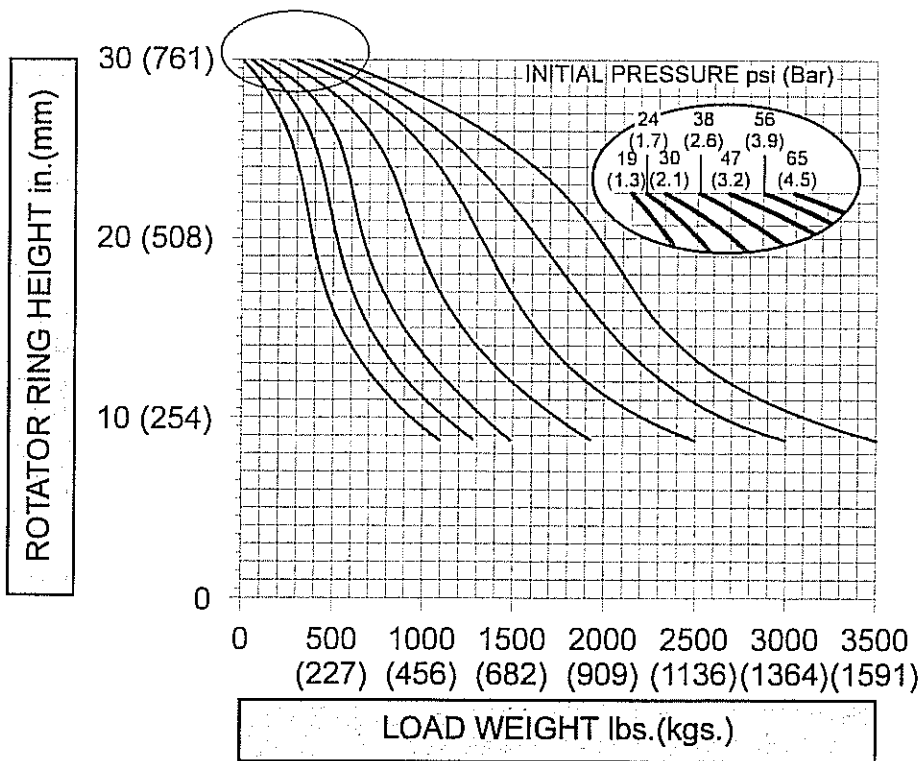

Figure 9 EZ-45 Height vs. Load Diagram

1. The EZ Loader must be properly installed before using. Refer to installation instructions on pages 7 and 8.
2. Pressurize the EZ Loader and disengage the maintenance bars if required. Otherwise, slowly open the purge valve to release the air from the system. The EZ Loader will completely collapse. Close the purge valve.
3. If the total is known, use the appropriate Height Vs Load diagram and locate the initial pressure curve that corresponds to a collapsed capacity that is 75 percent of the total load. To start, always use an initial pressure that is slightly higher than required. If the total load is unknown the maximum initial pressure should be used.

EXAMPLE

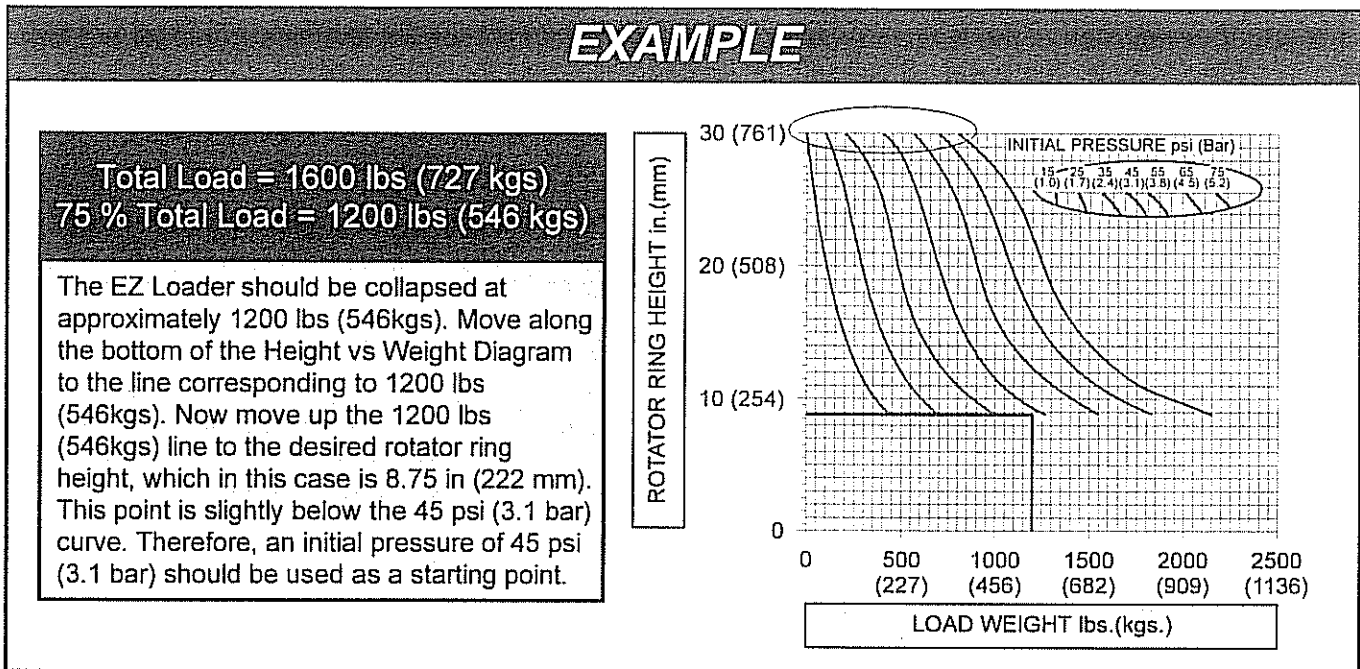

Figure 10 EZ-30 Height vs Weight Example

4. Set the air regulator to the required initial pressure and completely pressurize the EZ Loader. Check the pressure gauge on the EZ Loader to ensure the system pressure is the same as the regulator setting. Disengage the air chuck from the tank valve and store the air line in a convenient location.
5. Place the pallet and 75 percent of the total load on the EZ Loader. Check the platform height. If the EZ Loader is not completely collapsed, open the purge valve slowly and release air until the minimum height is obtained. Close the purge valve.
6. Using a fork lift, remove the loaded pallet and allow the EZ Loader to return to its raised position. If a dedicated air line is being used, set the air regulator to the initial pressure on the gauge. Otherwise, record the setting for future use.
7. The EZ Loader is now ready for use. Should the load capacity vary, adjustments in the load height or collapsed capacity can easily be made by adding or removing air from the system.

NOTE: The EZ Loader is a captive air system much like an automotive tire and will lose small amounts of air over a period of time. Therefore, air will have to be occasionally added to the system.

OPERATING INSTRUCTIONS

Loading Operations

1. Place the empty pallet on the EZ Loader rotator ring. Be sure that the pallet is centered on the rotator ring before beginning.
2. Begin the loading process. Always uniformly distribute each layer of load over the pallet surface. As the load weight increases, the EZ Loader will gradually lower to maintain the top of the load at a convenient working height.
3. Upon completion of the loading process, rotate the pallet to a position that is suitable for the fork lift forks to enter the pallet. Slowly lift the loaded pallet until the bottom of the pallet clears the top of the EZ Loader. Next, slowly back up until the load is well clear of the EZ Loader's operating zone and others. Then, lower the load to a convenient height for transportation.

Unloading Operations

4. Using a fork lift, lift the loaded pallet to a height where the bottom of the pallet clears the top of the EZ Loader. Position the loaded pallet over the top of the EZ Loader's rotator ring. Be sure that the pallet is centered over the rotator ring before lowering the load. Slowly lower the load until the EZ Loader is completely collapsed. Next, slowly back up until the forks are well clear of the EZ Loader's operating zone.
5. Begin the unloading process. Always remove each layer of load completely before beginning the next layer. This will ensure that the remaining layers are uniformly distributed over the pallet surface. As the load weight decreases, the EZ Loader will gradually raise to maintain the top of the load at a convenient working height.
6. Upon completion of the unloading process, remove the empty pallet.

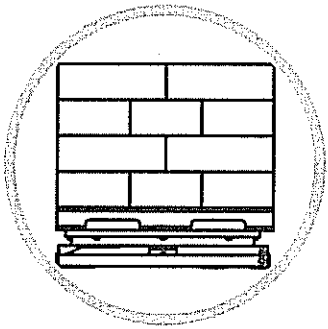
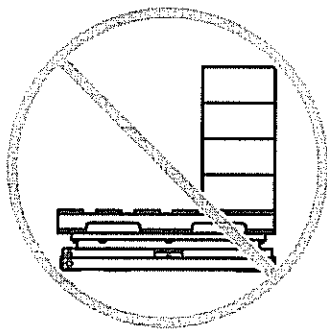
	<p style="text-align: center;">▲WARNING</p> <p>The EZ Loader is designed for use with stable, uniformly distributed loads on a solid level floor. DO NOT concentrate the load at one point on the pallet or platform. ALWAYS uniformly distribute each layer of load over the supporting surface. DO NOT use the EZ Loader for any purpose other than its intended use.</p>	
---	---	---

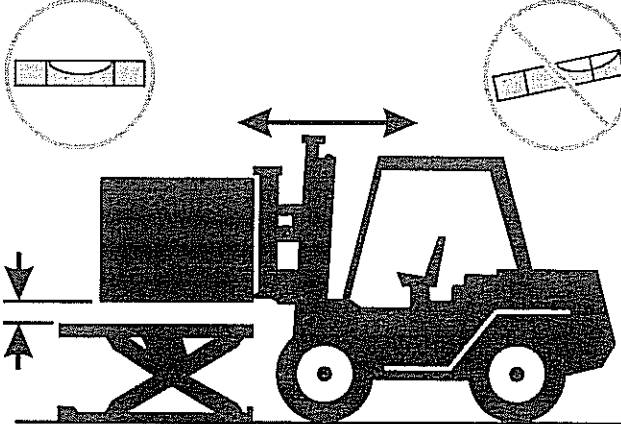
	<p style="text-align: center;">▲WARNING</p> <p>When removing a loaded pallet, ALWAYS raise the load until the bottom of the pallet clears the top of the EZ Loader before backing up. ALWAYS stay well clear of the load while it is being removed from the EZ Loader. SEVERE PERSONAL INJURY and PROPERTY DAMAGE could result.</p>
---	--

HANDLING INSTRUCTIONS

Bishamon recommends securing the EZ Loader to the floor for maximum stability. However, certain applications require the EZ Loader to be relocated frequently. Handling the EZ Loader can be easily accomplished as follows:

1. Remove all load from the platform and allow the EZ Loader to extend to its fully raised position.
2. Using a fork lift, position the forks under the platform structure, as detailed in Figure 7.
3. Slowly lift the EZ Loader until the base frame clears the floor. The EZ Loader can now be moved to the next location.

ROUTINE MAINTENANCE

The EZ Loader is designed to provide years of trouble free service and requires very little maintenance. However, a routine inspection and maintenance program will prevent costly replacement of parts and/or downtime.



NEVER go under the platform until the load is removed and the scissor mechanism is blocked. SEVERE PERSONAL INJURY could result.

Monthly inspection should consist of the following:

1. Inspect snap rings at all rollers and linkage assemblies. If not in place and/or secure, replace or repair at once.
2. Inspect all rollers for signs of wear. Replace as necessary. Rollers and axles have lifetime lubricated bearings; therefore, they do not need to be greased or lubricated.
3. Inspect the air spring retaining screws for tightness. Tighten if necessary.
4. Inspect the rotator ring bearings for ease of operation. Replace if necessary.
5. Should removal of the air lines be required, mark the initial position before removing the fitting nut. When reinstalling, first tighten the nut by hand, then using a wrench rotate the nut to the original position. Tighten the nut an additional 1/8 turn. Do not over tighten as air leakage may occur.

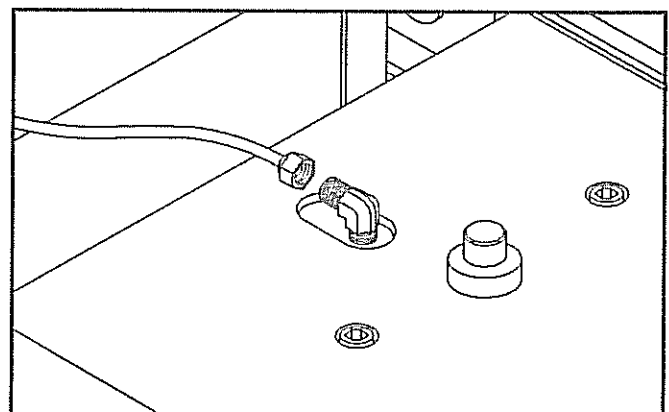
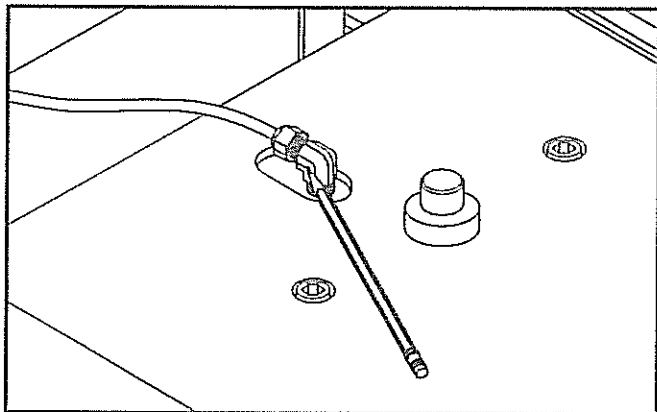

Figure 11 Fitting Disassembly

Monthly lubrication should consist of the following:

1. For EZ Loaders equipped with the optional semi-live portability, lubricate the stop arm assembly and the wheel arm assembly with silicon spray to ensure ease of movement.

WARNING

DO NOT inflate the air spring when removed from the EZ Loader. Pressurizing the unrestricted air spring may cause assembly to burst. **SEVERE PERSONAL INJURY** and **PROPERTY DAMAGE** could result.

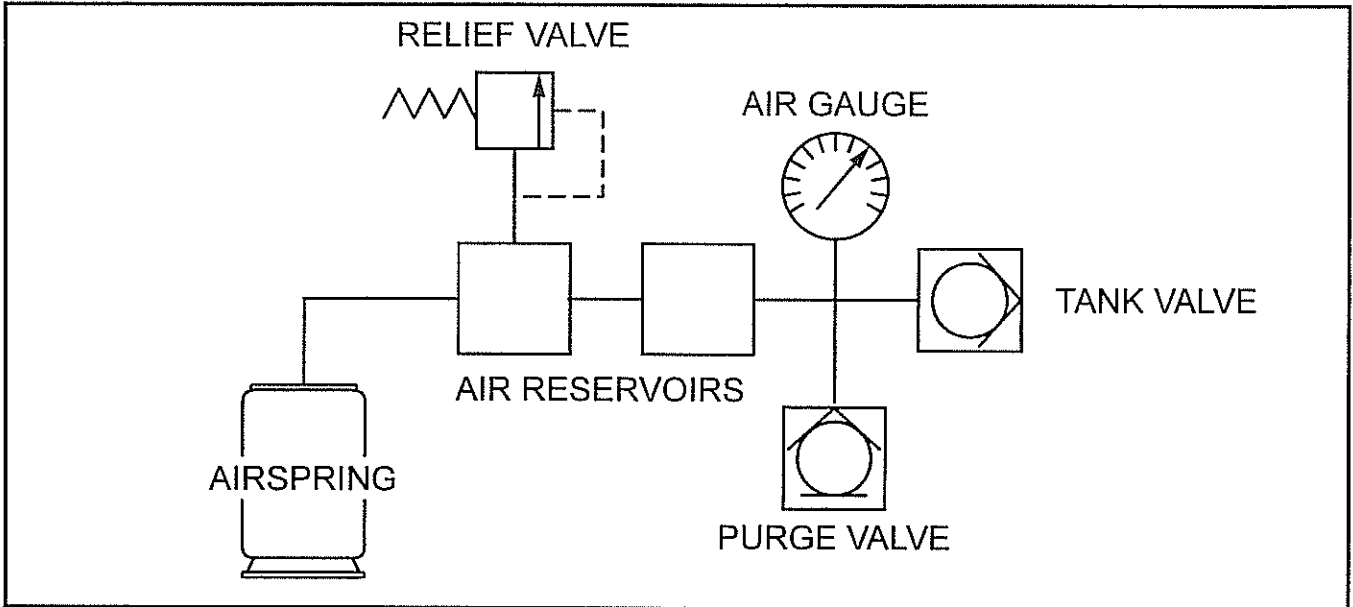

Figure 12 EZ Loader Pneumatic Schematic

REPLACEMENT PARTS

Bishamon has carefully selected the components used in the manufacture of the EZ Loader. In the event replacement parts are required, **ALWAYS** use genuine EZ Loader components provided by Bishamon. These parts can be obtained from your Bishamon DEALER or by contacting Bishamon Industries Corp.