

# LEVEL-LIFTER

## Ground Entry Lift Tables

Photo eye to interrupt lowering in the event of an obstruction.

Platform of 1/2" plate steel and unique multi-point lift offers minimal deflection.

Rear compartment houses a 1 1/2 HP motor, single stage cylinder, gear type pump, and a recessed 115 volt receptacle. Hydraulic velocity fuse is standard. Push button magnetic backed control box standard. Foot switch – optional.

Limit switch for controlling upward maximum travel.

Totally enclosed sides are only 2-1/2" wide. This eliminates excessive reaching for product and also acts as a barrier between the operator and moving platform.

Portability. Align platform and pin through to convert platform into a support for pallet jack.

Lip is beveled into platform a full 3" to allow for smooth entry even with a hand pallet truck.

*Lift Products, Inc. products are covered by Patents Pending and other rights reserved. Specification subject to change without notice.*

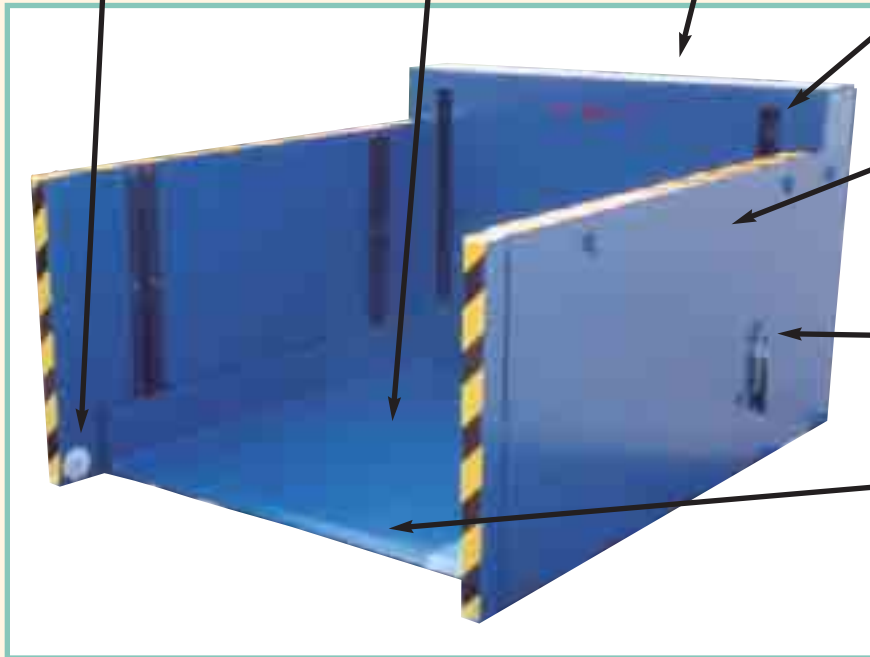

Capacity: 2500 lbs. to 4000 lbs.  
Useable Platform: 44" x 50"  
Lowered: 1/2"

Lift Height:		A	B
	24"	31"	37"
	30"	37"	43"

### Special Options Available

- Stainless Steel Deck
- DuPont Thermoplastic Polyethylene™ a FDA-Approved Finish
- Custom Sizes Available
- Foot Switch Control
- Photo-Eye Bypass Switch

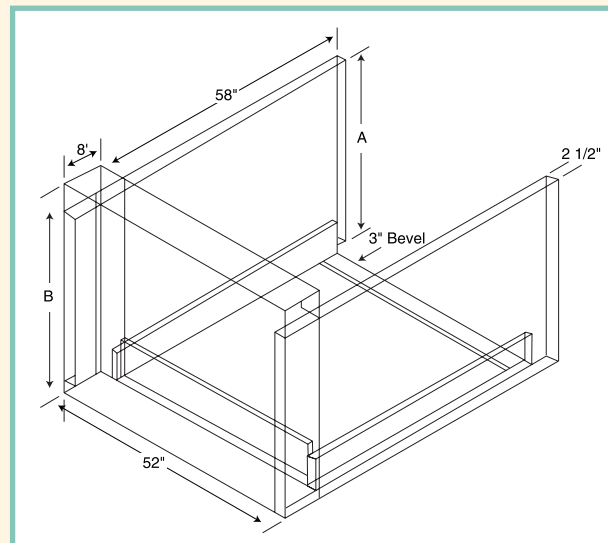

Loads can be adjusted to individual comfort level through the use of standard push button or optional foot switch control. Narrow sides allow easy access for load positioning.



Fully-raised height of 24" or 30" allows for convenient work height.



Lowered height of 1/2" maximizes accessibility to top level of load.

Loading or unloading, the Level-Lifter offers a smooth transition, and is ideal for use with a powered or hand pallet truck.

## Level Lifter - Ground Entry Lift Table

Usable Platform: 44" x 50"

MODEL	CAPACITY lbs.	RAISED HEIGHT	SHIP WT. lbs.
LL-24-25-4450	2,500	24"	2,040
LL-24-30-4450	3,000	24"	2,090
LL-24-35-4450	3,500	24"	2,140
LL-24-40-4450	4,000	24"	2,190
LL-30-25-4450	2,500	30"	2,340
LL-30-30-4450	3,000	30"	2,390
LL-30-35-4450	3,500	30"	2,440
LL-30-40-4450	4,000	30"	2,490



The Level-Lifter is portable too! Raise the platform to pin height, insert pins, and reposition.

## Printer Edition LEVEL-LIFTER with Optional Adjustable Corner Board

- Available in either an adjustable or rigid version.
- Perfect for squaring loads.
- Keeps loads stable and rigid.
- Custom sizes available.

