

STAINLESS STEEL USDA Approved Lifts

Ideal for use in wash down areas, these tables have a passivated sanitary finish and all dead end spaces have been eliminated. In addition to the many ergonomic benefits derived by using lift tables, these units also meet the complex requirements demanded by the food processing, chemical and pharmaceutical industries.

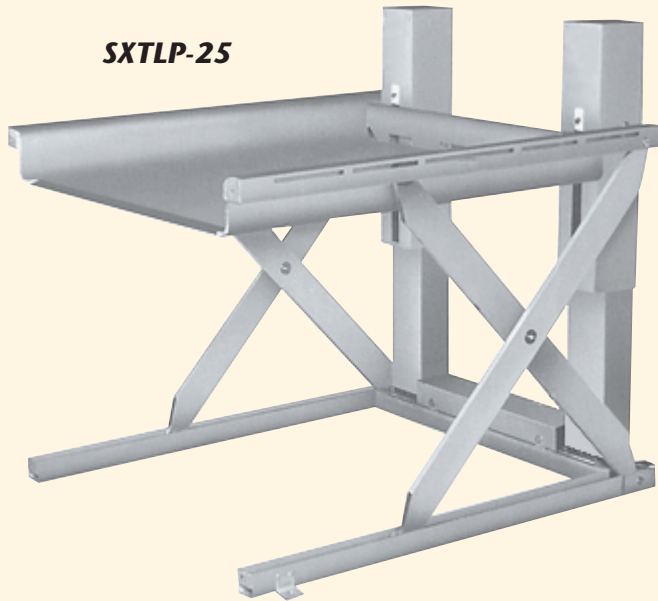

SXTLP-25

Model SXTLP-25 Ground Entry Lift Table

Featuring our
exclusive passivated
finish for in-place
wash down

- T304 Stainless steel construction
- Passivated finish for in-place wash down
- Platform size: 42" x 48"
- Base size: 48 1/4" x 54 3/4"
- Capacity: 2,500 lbs.
- Elevation Time: 20 seconds
- Descent Time: 8 seconds
- Self contained stainless steel enclosed power unit
- Actuation: Dual, low pressure hydraulic cylinders, white epoxy SST powder coated
- 110 volt AC TEFC Motor providing 1 HP output

Model SXT-040-36 Scissor Lift Table

- T304 Stainless steel construction
- Passivated finish for in-place wash down
- Platform size: 42" x 48"
- Base size: 35 1/2" x 45"
- Capacity: 4,000 lbs.
- Elevation Time: 30 seconds
- Descent Time: 24 seconds
- Self contained stainless steel enclosed power unit
- Push button pendant
- Dual, low pressure hydraulic cylinders, white epoxy SST powder coated
- 110 volt AC TEFC Motor providing 1 HP output

Platform Raised Height: 36"

Platform Lowered Height: 9"

Options:

- Rotating Top
- Semi-Portable
- Foot Control
- Custom Sizes Available

Side Rail Height: 6"

Platform Raised Height: 37"

Platform Lowered Height: 1/2" w/beveled front edge

Pedestal Lowered Height: 35 1/2"

Pedestal Raised Height: 55"



SXT-040-36