

# **SOUTHWORTH**

## **Owner's Manual**

# **DANDY LIFT**

For model numbers UDL-150, UDL-250, UDA-350W, UDA-500 & UDA-800,  
this manual is for Serial number L-248493 and up,  
and for machines manufactured in September 2011 and newer.

For older machines, contact Southworth Parts Department.



Model # \_\_\_\_\_

Serial # \_\_\_\_\_

Placed in Service \_\_\_\_\_

**Southworth Products Corp**

P.O. Box 1380, Portland, Maine 04104-1380

Phone 800/743-1000 or 207/878-0700 Fax 207/797-4734

[www.SouthworthProducts.com](http://www.SouthworthProducts.com)

[Service@SouthworthProducts.com](mailto:Service@SouthworthProducts.com)

May 2013

Please note: This manual was current at the time of printing. To obtain the latest, most updated version, please contact Southworth's Customer Service Department or go to our website: [www.SouthworthProducts.com](http://www.SouthworthProducts.com), under the Parts & Service tab you will find a complete list of current owner's manuals to print.

# Contents

INTRODUCTION .....	Page 4
SPECIFICATIONS .....	7
OPERATING INSTRUCTIONS .....	8
Raise/Lower.....	8
Loading/Unloading.....	8
INSPECTION & MAINTENANCE .....	9
ILLUSTRATED PARTS LIST .....	13
ORDERING REPLACEMENT PARTS .....	22
WARRANTY .....	Back of manual

## List of Figures

Fig. N1-1 Platform.....	14
Fig. N1-2 Scissor Device (UDL-250, UDA-500 & UDA-800) .....	14
Fig. N1-2' Scissor Device (UDA-350W).....	15
Fig. N1-4 Handle Assembly .....	15
Fig. N1-5 Jack Assembly .....	16
Fig. N1-6 Caster .....	16
Fig. N1-7 Parking Lock .....	16
Fig. N1-8 Release Lever Assembly .....	17
Fig. N1-9 Jack Pedal Assembly .....	18
Fig. S-1 Platform.....	19
Fig. S-2 Scissor Device (UDL-150) .....	19
Fig. S-4 Handle Assembly (UDL-150) .....	19
Fig. S-5 Jack Assembly (UDL-150) .....	20
Fig. S-6 Caster (UDL-150).....	20
Fig. S-7 Parking Lock (UDL-150) .....	20
Fig. S-8 Release Lever Assembly (UDL-150) .....	21
Fig. S-9 Jack Pedal Assembly (UDL-150) .....	21

Exclusively developed hydraulic jack has excellent reliability and durability allowing it to last for about 400,000 strokes.

Serial numbers and manufactured date which marked on die on each brass plate are registered in manufacture's book. The number and date show individual identity and please keep the record prior to use the unit.

## **PRIOR TO OPERATING THE LIFT:**

The UD Dandy Lift is designed to provide safe operation. By following these safety rules, the operator will avoid injury to him/her self or others and also damage to the Dandy Lift, other equipment or structures.

In order to ensure safe and efficient use, the operator should fully familiarize himself with the contents of this manual prior to handling the unit. Also refer to any precautionary labeling on the machine for guidance as you do the work.

### **WARNING**

1. Keep non-authorized personnel away from the unit during operation.
2. Do not sit, stand or ride on the tabletop.
3. Do not load with more than the rated capacity.
4. Avoid any protrusion beyond the edge of the platform; load should always be centered.
5. Keep hands or feet clear at all times.
6. Avoid rapid lowering of the platform while loaded.
7. The platform must be lowered when the unit is being transported.
8. During the loading/unloading operation, do not release parking brake.
9. Do not raise/lower the platform on a sloped or uneven surface.

For safe and efficient use of the unit, lubrication and servicing is necessary. At initial start up, lubricate all required parts in accordance with lubrication section.

Maintenance and adjustment work must be performed while lift is not loaded, and use an appropriate support to avoid accidental lowering. This support is always recommended when working on a lift.

## GENERAL INFORMATION & OPERATION

### UDL-150, UDL-250, UDA-350W, UDA-500, UDA-800

A. The lift is packed in a cardboard box. Assembling of the handle with lift-lowering lever and jack up pedal is required.



#### **WARNING:**

Assembly work must be done on a flat surface.  
Wheels must be chocked to prevent accidental rolling of the unit.

#### **To complete assembly of the lift:**

1. Remove nuts and spring washers from the end of handle and insert the handle and lowering lever rod simultaneously into hole on platform and frame. If rod end of lowering lever slips out of the connecting sleeve or wedge of rod end does not hold in the connecting sleeve, adjustment may be required. Tighten handle and lowering lever using removed nuts and washers.

B. If air enters the hydraulic pump during transportation or in storage, lift may not raise even when the pedal is first pumped. In this case, place the unit in the normal position and push the pedal all the way down (approximately ten times). This should clear the trapped air from the self-bleeding system. Check to see that the jack is functioning properly.

C. Parking brake (floor lock) will require adjustment. Adjust the contact shoe so that you can see it make contact with the floor with some force and then make sure it can still be released without difficulty.

## General View of UDL-150, UDL-250, UDA-500, UDA-800 and UDA-350W

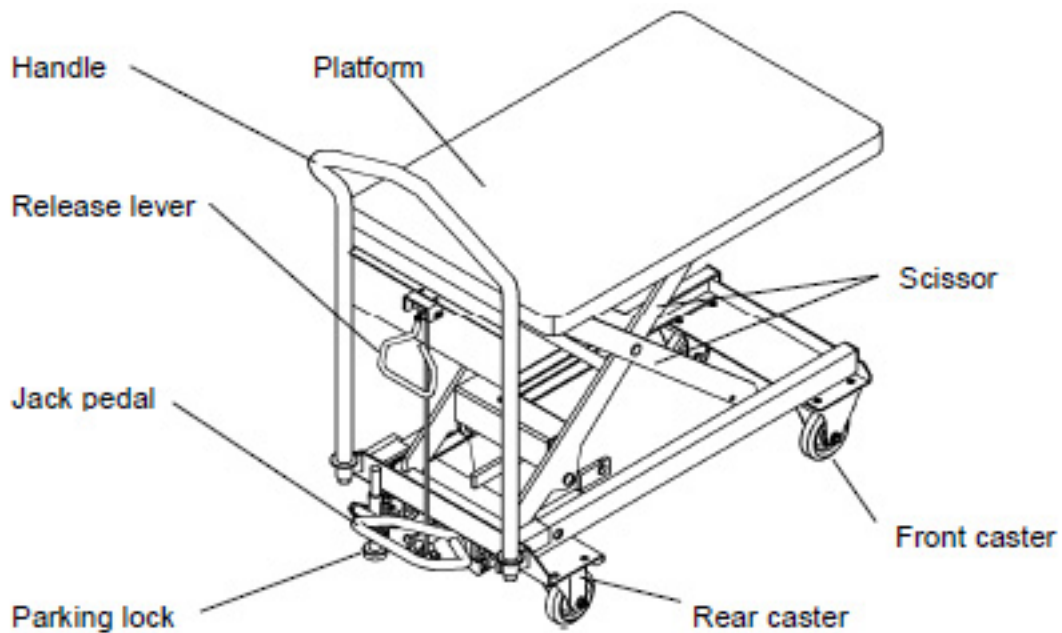

### 2. Assembly

A) Please take out, handle assembly and Jack pedal.

B) Remove hexagon bolt and nylon nut from Jack Pedal. Then put the Jack Pedal in to Jack Pedal receiver. (Fig. 2)

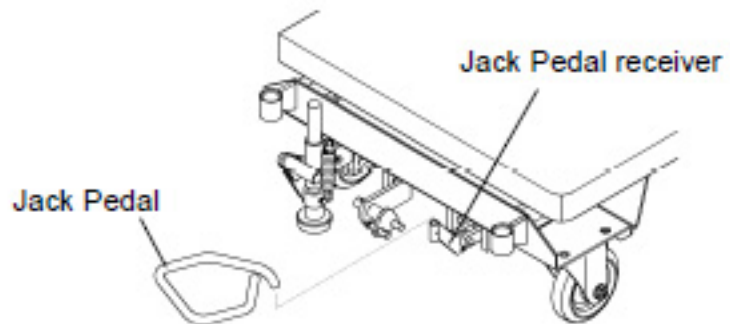

C) Please remove nut and spring washer and then put in handle assembly to bottom frame. (Fig. 3) Then the Release Lever Rod will go to right side of crank. (Fig. 4)

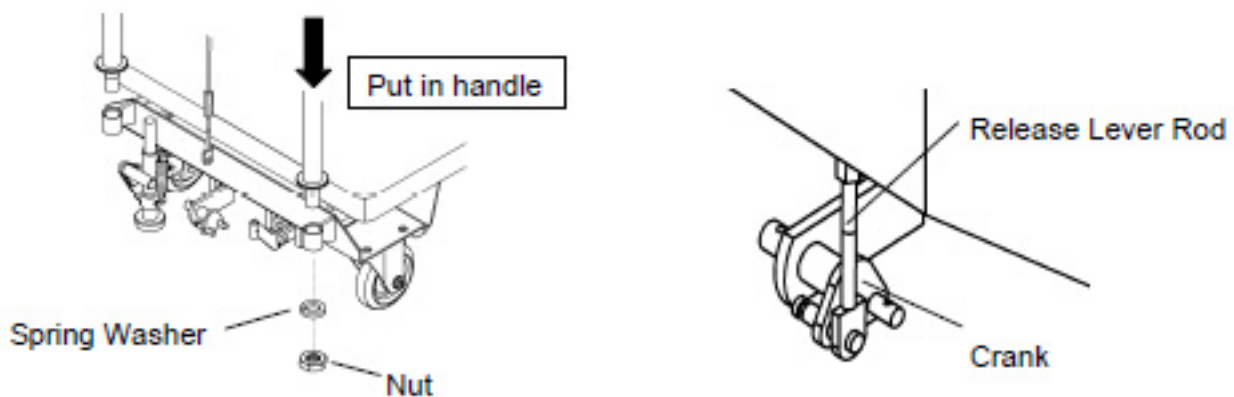

## SPECIFICATIONS

MODEL	UDL-150	UDL-250	UDA-500	UDA-800	UDA-350W
CAPACITY – lb. (kg.)	330 (150)	550 (250)	1100 (500)	1760 (800)	770 (350)
PLATFORM LOWERED HEIGHT – inches (mm)	8.3 (210)	9.5 (245)	11.8 (300)	13.0 (330)	13.6 (345)
VERTICAL TRAVEL – inches (mm)	20.7 (525)	22.2 (565)	24.8 (630)	27.2 (690)	36.2 (920)
PLATFORM RAISED HEIGHT – inches (mm)	29.0 (735)	31.8 (810)	36.6 (930)	40.1 (1020)	49.8 (1265)
HANDLE HEIGHT – inches (mm)	35.0 (885)	36.4 (925)	37.9 (965)	38.1 (970)	37.9 (965)
PLATFORM W x L – inches (mm)	17.7 x 28.0 (450 x 710)	19.7 x 31.5 (500 x 800)	23.6 x 35.8 (600 x 910)	23.6 x 39.4 (600 x 1000)	23.6 x 35.8 (600 x 910)
OVERALL W x L – inches (mm)	17.7 x 32.8 (450 x 875)	19.7 x 36.6 (500 x 930)	23.6 x 42.1 (600 x 1070)	23.6 x 45.8 (600 x 1165)	23.6 x 42.5 (600 x 1080)
FOOT PEDAL STROKES TO ELEVATE	15	20	45	55	45
FOOT PEDAL FORCE REQUIRED – lb. (kg)	77.0 (35)	52.8 (24)	59.4 (27)	88.0 (40)	66.0 (30)
CASTERS FRONT	4" RIGID	4" RIGID - HD	5" RIGID	6" RIGID URETHANE	5" RIGID
CASTERS REAR	4" SWIVEL	4" SWIVEL - HD	5" SWIVEL	6" SWIVEL URETHANE	5" SWIVEL
PARKING LOCK/ FLOOR LOCK	YES	YES	YES	YES	YES
COLOR – PLATFORM/FRAME	BLUE/BLUE	ORANGE/BLUE	YELLOW/BLUE	GRAY/BLUE	YELLOW/BLUE
TARE WEIGHT – lb. (kg)	85.8 (39)	118.8 (54)	193.6 (88)	250.8 (114)	231.0 (105)

Note: Casters are rubber except where noted. Specifications are subject to change without notice.

## Operation

### Raise/Lower

#### CAUTION:

**Lock parking brake securely. Do not raise/lower the platform on a sloped surface.**

**To raise:** Pump jack pedal repeatedly.

NOTE: If the platform did not lift up properly, adjustment must be made in accordance with the inspection and maintenance section.

#### WARNING:

**Keep hands or feet clear of the platform and the frame.**

**To lower:** Turn lowering lever slowly in a clockwise direction. As soon as the platform starts down, do not turn the lever more - maintain as is. The platform will continue lowering smoothly. The lowering operation must be made slowly. By turning the lever, lowering speed can be adjusted.

NOTE: When load is on the platform, turn lever only the minimum amount to prevent rapid descent of the platform. When the platform is empty, turn lever fully.

#### CAUTION:

**Adjust stopper bolt when lift lowers too rapidly.**

#### WARNING:

**Keep hands or feet clear of the platform and the frame.**

**To maintain the platform at an intermediate point:**

- The platform stops when pumping up pedal is stopped.
- When the lowering lever is released, the platform stops lowering and will maintain the position.

### Loading/Unloading

#### CAUTION:

**Do not allow load to overhang the edge of the platform.  
Do not load more than specified capacity.**

Parking Lock:

1. Parking brake (floor lock) must be actuated during parking and lifting or lowering of the platform.

In Running (brake off)



Parking (brake on)

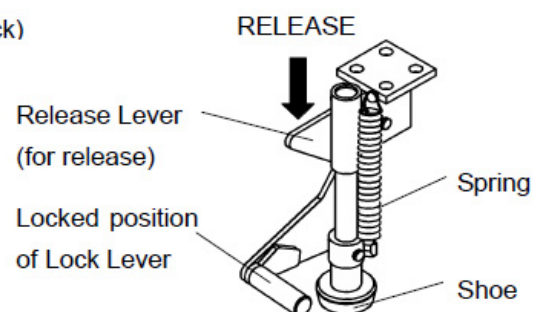

**WARNING:**

**Floor lock (parking brake) is fixed to prevent shoe from falling off during shipment. Do not actuate as is. The following adjustments must be made as soon as the unit is assembled.**

2. Adjustment of the shoe on the parking brake

- Adjustment work must be done on flat surface.
- Step on lock lever until it clicks actuating the brake.
- Screw shoe down by rotating it in a clockwise direction so that it touches the floor.
- Step on release lever to release the brake. Then rotate the shoe clockwise an additional two turns to provide firm contact with the floor.

NOTE: By doing the above adjustments, shoe will compress by 1/8", assuring firm contact with floor. If perfect braking is not achieved, repeat above adjustment. Required pushing force for lock lever will increase, but braking effect will increase.

**CAUTION:**

**Make sure floor lock is set during lifting or parking.**

**INSPECTION AND MAINTENANCE**

UD Dandy Lifts do not require special maintenance, other than lubrication and periodic inspection. Inspection and maintenance should be made in accordance with the following procedure for smooth and efficient operation.

**CAUTION:**

**During lubrication, inspection and maintenance the platform must be empty.**

**WARNING:**

**If the platform needs to be raised for access to lubrication points, the unit should be laid over on its side. Do not put your hands into a raised lift.**

NOTE: The following are recommended as support and must be fixed to the frame using adhesive tape. Supports of the following size are recommended:

	Width (in.)	Length (in.)
UDL-150	3/4 x 3/4	11
UDL-250	3/4 x 1-1/2	12
UDA-350W	3/4 x 1-1/2	9
UDA-500	3/4 x 1-1/2	14
UDA-800	3/4 x 1-1/2	15

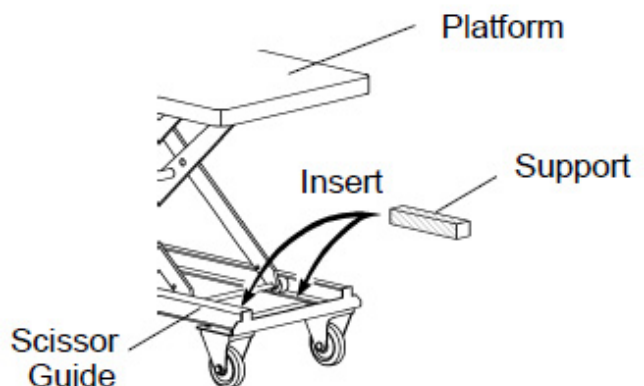

## A. Lubrication

Lubrication must be made in accordance with the following table:

Part	Lubrication Material	Fig. & Item No. To be referred
Rail (Frame)	Grease	N1-3*(S-3)
Roller (of Jack Lever)	Grease (Grease Nipple)	N1-9-12 (S-9-12)
Hinge on Scissor	Machine Oil	N1-2-1 (S-2-1-1)
Stay	Machine Oil	N1-2-4 (S-2-4)
Lifting-up Box (moving part)	Machine Oil	N1-2-1-2 (S-2-1-2) N1-2-3
Parking Lock	Machine Oil	N1-7* (S-7)
Lowering Lever (moving part)	Machine Oil	N1-8* (S-8)
Jack Pedal	Grease, One (1) (Grease Nipple)	N1-9-4 (S-9-2)
Other Contacting and Sliding Area	Grease/Machine Oil	
Jack Oil	EP-32 or Equivalent	

\*( ) Is to be applied to UDL-150 Only

## B. Inspection and Maintenance

Prior to use of the unit, check for any damage, deformation or cracks on the body.

NOTE: During inspection, the platform must be empty.

Remove foreign substance on scissors guide from the frame and rail.

- Check lifting performance of the platform in accordance with provision of operation.
- Check stopping performance at any desire height.
- Check lowering speed and smooth action of the lowering lever.

## C. Adjustment

### 1. Malfunctioning up/down of the platform.

If the platform does not lift up or hold in any position even while jack is pumped.

- Air is in the jack unit  
To bleed jack unit: Pump for three seconds and repeat a few times, then keep the unit as is for about ten minutes. If air bubbles are not purged yet, repeat above adjustment once more.
- Jack valve does not close perfectly  
Valve on jack will not be closed perfectly. In this case, adjustment is required in accordance with the procedure on the next page:

For UDL-150, UDL-250, UDA-350W, UDA-500 and UDA-800  
Loosen nut on connecting rod-1 and turn part (A), shown in right figure, in counter-clockwise direction one turn.

Tighten the nut preventing turn of above (A).

Check for normal raising and lowering of the platform by pushing pedal.

If the above adjustment does not result in normal operation, repeat once more.

If the above adjustment does not result in normal operation, check for problem in other parts.

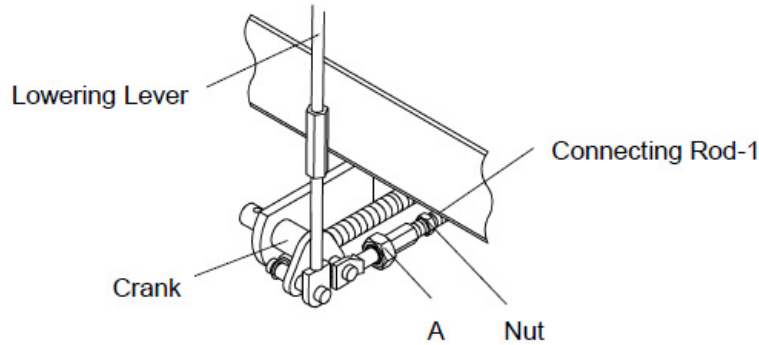

## 2. Adjustment of lowering speed of the platform.

In case the speed is abnormal, adjustment is required as follows:

- To take off the R-pin of center rod and washer.
- To adjustment release of release lever rod. To change the degree of release lever rod. The right one is perpendicular with release lever.
- After adjustment, to assemble from center rod, washer to R-pin.

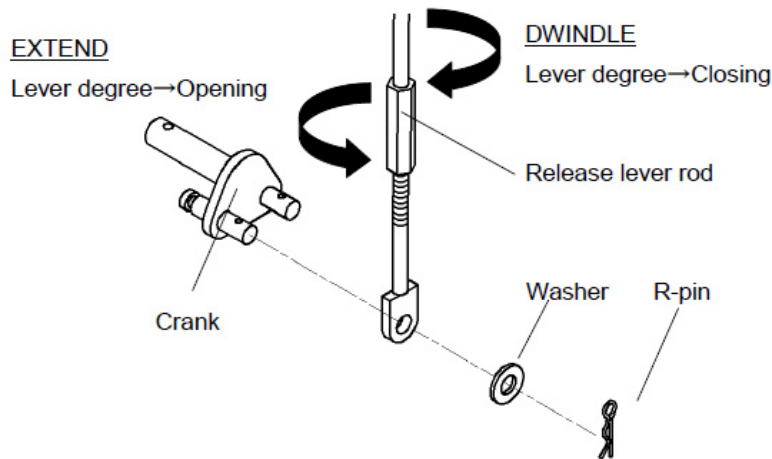

#### D. Removing Scissor Assembly

1. Raise table up to maximum height and insert a maintenance support in scissor guide.
2. Loosen and remove screw (P/N 0218825) from lift box.

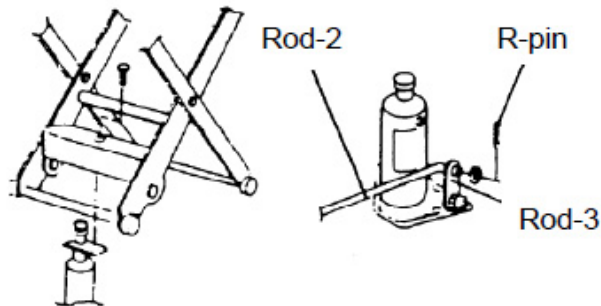

Longer Support		Length	Section	
For	UDA-350W	A 7"	1"×1 1/2"	
		B 3 1/4"	1"×1 1/2"	
For	UDL-150	A 11 1/2' 1"×1 1/2"		
		(B size is not useable)		
	UDL-250	A	9 7/8"	1"×1 1/2"
	UDA-500			
	UDA-800	B	3 1/4"	1"×1 1/2"

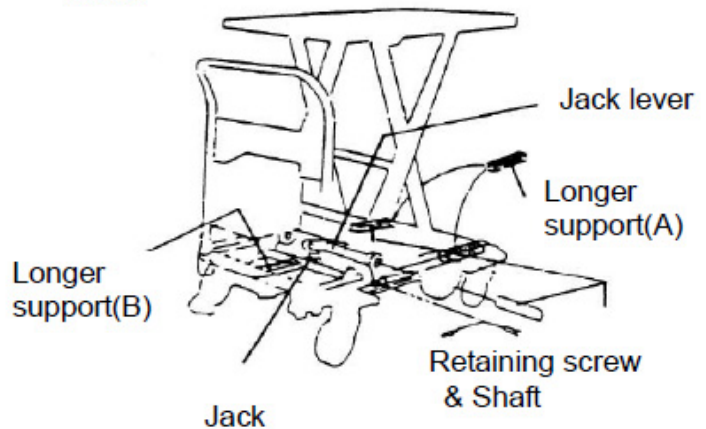

3. Remove a support from scissor guide and lower platform to lowest position using lowering lever. Then raise platform again by hand as high as possible. Supporting both front and rear edges as shown in above sketch. Then insert longer support, which are used in above 1., to both front and rear scissor guide and fix these using tape to prevent accidental lowering platform. (Refer to above sketch).
4. This connecting rod-2 and -3 by removing "R" pin (P/N 0340808) from the end of connecting rod-2 of lowering lever assembly.
5. Prior to removing jack, remove jack lever with following sequence:
  - a) Remove retaining screw(P/N 0212410), For UDL-150, remove ring "C" (P/N 0321601)
  - b) Draw out shaft (P/N ND140061), (P/N NA410082 for UDL-150)
  - c) Remove jack lever (P/N ND410011 or NB41001J, (P/N UNA401010 for UDL-150)
6. The above disconnects the jack from all connected linkages. Then the jack can be removed by loosening mounting bolts of jack.
7. Reverse the above sequence for installation of jack.

## ILLUSTRATED PARTS LIST

For models UDL-250, UDA-500, UDA-800 and UDA-350W, refer to Figure 1 (item N) illustration and part number against Figure 2 (item S) for UDL-150.

To place your parts order, both model and serial number must be specified together with name of each parts and required quantity.

For example:

Model No.	Serial No.	Item No.	Name & (P/N)	Quantity
UDA-500		N-6-1	Front caster (P/N 38WK 125R)	1

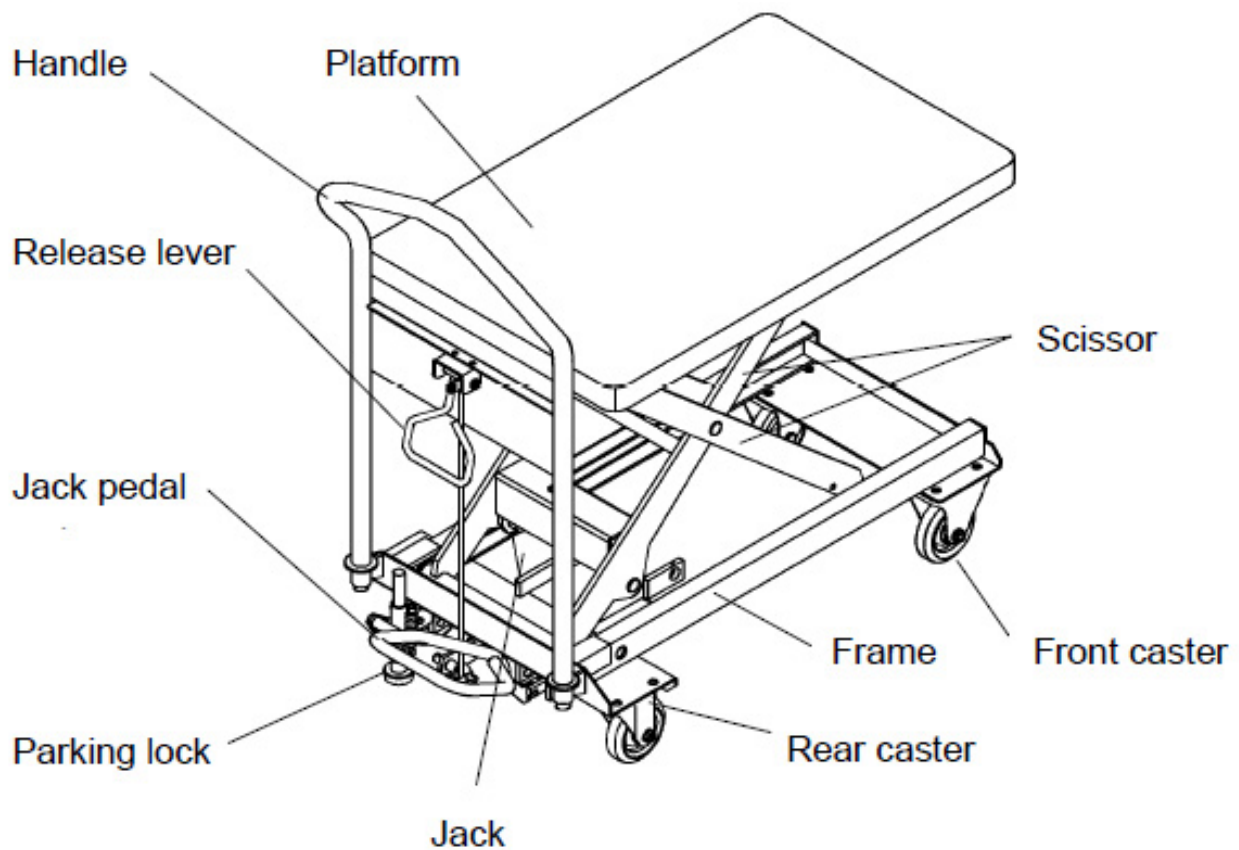
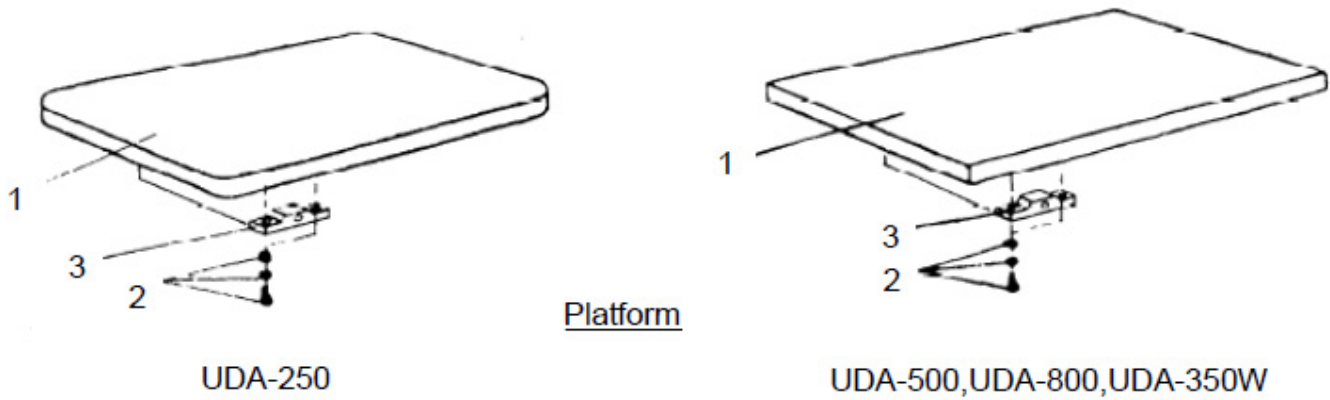
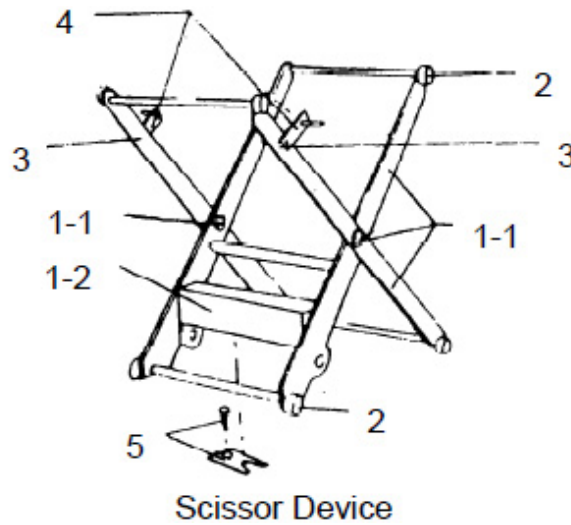

Fig. N1-1 Platform



Item No	Description	Qty	UDL-250	UDA-500	UDA-800	UDA-350W
N1-1	Platform	1				
-1	Platform Plate	1	NB201010	ND201010	NE201010	NC201010
-2	Screw & Nut Washer, Spring	4 4	0218820 0980856	0218825 0980853	0218825 0980853	0218820 0980853
-3	Plastic fitting for Stay	2	ND391032	ND391032	ND391032	ND391032

Fig. N1-2 Scissor Device for UDL-250, UDA-500 & UDA-800



Item No	Description	Qty	UDL-250	UDA-500	UDA-800
N1-2	Scissor Device	1			
-1-1	Scissor (Outer) Scissor (Inner) Pin, Pivot	1 1	NB310012 NB320012 NB370000	ND310011 ND320010 ND340070	NE310010 NE320010 NE340070
-1-2	Lift Box Pin, Pivot Ring, Retaining	1 2 2	NB340012 NB350002 0321601	ND340011 ND350001 0322001	NE340011 NE350001 0322501
-2	Roller (Upper) (Lower)	4 4	NB351002	ND351001 ND361001	NE351001 ND361001
-3	Washer	2	0910812	0910812	0910812
-4	Stay	2	ND391012	ND391012	ND391012
-5	Jack Plate Screw	1 1	NB340050 0218825	ND351051 0218825	NE350050MA 0218825

Item No	Description	Qty	UDA-350W
N1-2'	Scissor Device	1	
-1-1	Scissor (Lower)	1	NC320011 (out side) NC310010 (in side)
-1-2	Scissor (Upper)	1	NC32001B (out side) NC31001B (in side)
	Pin, Pivot	4	ND340070
-1-3	Lift Box	1	NC340011
	Ring, Retaining	2	0322001
-2	Roller (upper)	4	ND351001
	(lower)	4	ND361001
-3	Washer	2	0910812
-4	Stay	2	ND391012
-5	Jack Plate	1	ND340051
	Screw	1	0218825
-6	Guide	1	NC190010
	Bolt	1	0111020
	Washer, Spring	1	0981014

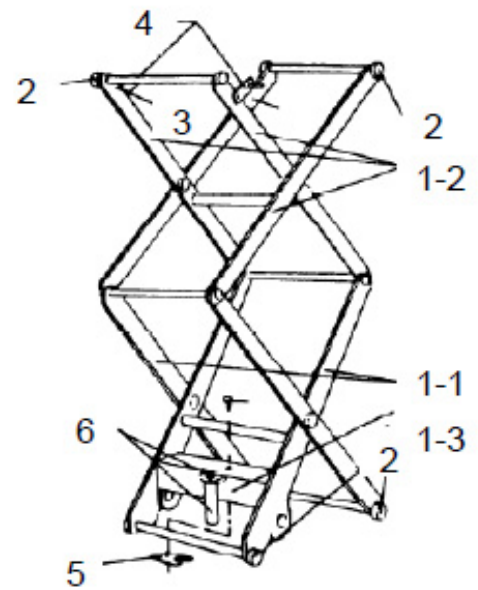

**Scissor Device UDA-350W**

Fig. N1-2'

Item No	Description	Qty	UDL-250	UDA-500	UDA-800	UDA-350W
N1-3	Frame (not illustrated)	1	NB101002	ND101002	NE101001	NC101001

Item No	Description	Qty	UDL-250	UDA-500	UDA-800	UDA-350W
N1-4	Handle Assy	1				
-1	Handle with name plate	1	NB221012	ND220011	ND220011	ND220011
-2	Nut	2	0812011	0812011	0812011	0812011
	Washer, Spring	2	0982057	0982057	0982057	0982057

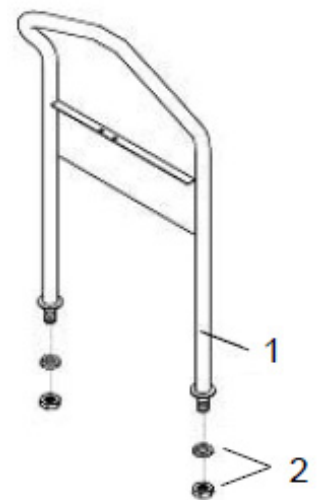
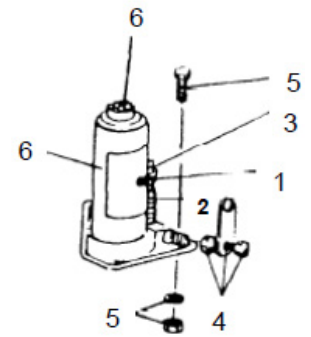

Fig. N1-4

**Handle Ass'y**

Item No	Description	Qty	UDL-250	UDA-500	UDA-800	UDA-350W
N1-5	Jack Assy	1	*(NA511AA1)	*(ND511AA1)	*(NE521AA0MA)	*(ND511AA1)
-1	Piston	1	ND520010	ND520010	NE520010MA	ND520010
-2	Spring, Compression	1	NB531001	ND531001	NE531001	ND531001
-3	Cap Pin, Spring	1 1	ND540010 0460820	ND540010 0460820	NE540010 0460820	ND540010 0460820
-4	Nut "U" Connecting Rod-3	1 2	0810881 ND741010	0810881 ND741010	0810881 ND741010	0810881 ND741010
*-5	Bolt Nut Washer, Spring	2(4) 2(4) 2(4)	0110825 0810811 0980853	0110825 0810811 0980853	0110830 0810811 0980853	0110825 0810811 0980853
-6	Jack	1	NA510000	ND510000	NE510000MA	ND510000



Jack Ass'y

Fig. N1-5

\*Bolt, Nut & Washer Spring are not included in the jack assembly on the top line above.

\*Qty of 3 pieces are to be used for UDA-800

Item No	Description	Qty	UDL-250	UDA-500	UDA-800	UDA-350W
N1-6	Caster	(4 Sets)				
-1	Front caster	2	38-WK-100R	38-WK-130R	38-WK-150U	38-WK-125R
-2	Rear caster	2	38-WJ-100R	38-WJ-130R	38-WJ-150U	38-WJ-125R
-3	Bolt Washer, Spring Nut	16 16 16	0141020 0981064 0811011	0141020 0981064 0811011	0141020 0981064 0811011	0141020 0981064 0811011

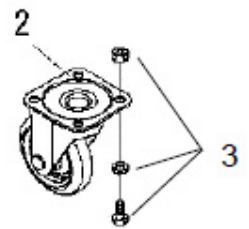
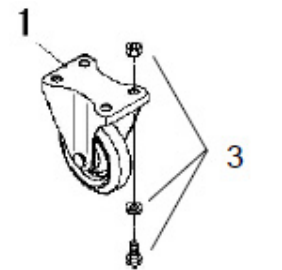

Caster

Fig. N1-6

Item No	Description	Qty	UDL-250	UDA-500	UDA-800	UDA-350W
N1-7	Parking Lock	1				
-1	Floor Lock	1	ND810000	ND810000	ND810000	ND810000
-2	Bolt	4	0110820	0110820	0110820	0110820
-3	Washer, Spring	4	0980853	0980853	0980853	0980853
-4	Nut	4	0810811	0810811	0810811	0810811

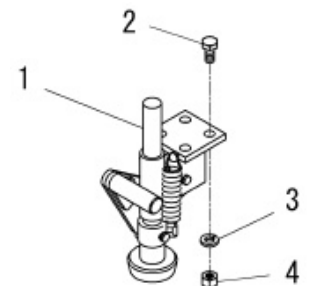

Parking lock

Fig. N1-7

Item No	Description	Qty	UDL-250	UDA-500	UDA-800	UDA-350W
N1-8	Release Lever Assy	1				
-1	Release Lever	2	NUD220100	NUD220100	NUD220100	NUD220100
-2	Pin, Spring	2	0460422	0460422	0460422	0460422
-3	Spring	2	NB760000	ND760000	ND760000	ND760000
-4	Fixed Support	1	UND720010	UND720010	UND720010	UND720010
-5	Screw	1	0210816	0210816	0210816	0210816
-6	Release Lever Rod	1	UNB461A1S	UND461A1L	UND461A1L	UND461A1L
-7	Connecting Rod	1	UNB741061	UND740061	UNE740061	UNC740061
-8	Release Rod	1	UND461B04	UND461B04	UND461B04	UND461B04
-9	Crank	1	UND740031	UND740031	UND740031	UND740031
-10	Washer	1	0910813	0910813	0910813	0910813
-11	Pin, "R"	1	0340808	0340808	0340808	0340808
-12	Nut "U"	2	0810882	0810882	0810882	0810882
-13	Screw	1	0216616	0216616	0216616	0216616
-14	Washer, Spring	2	0980652	0980652	0980652	0980652
-15	Nut	2	0810611	0810611	0810611	0810611
-16	Bolt	1	0110865	0110865	0110865	0110865
-17	Washer, Spring	1	0910813	0910813	0910813	0910813
-18	Nut	1	0810812	0810812	0810812	0810812

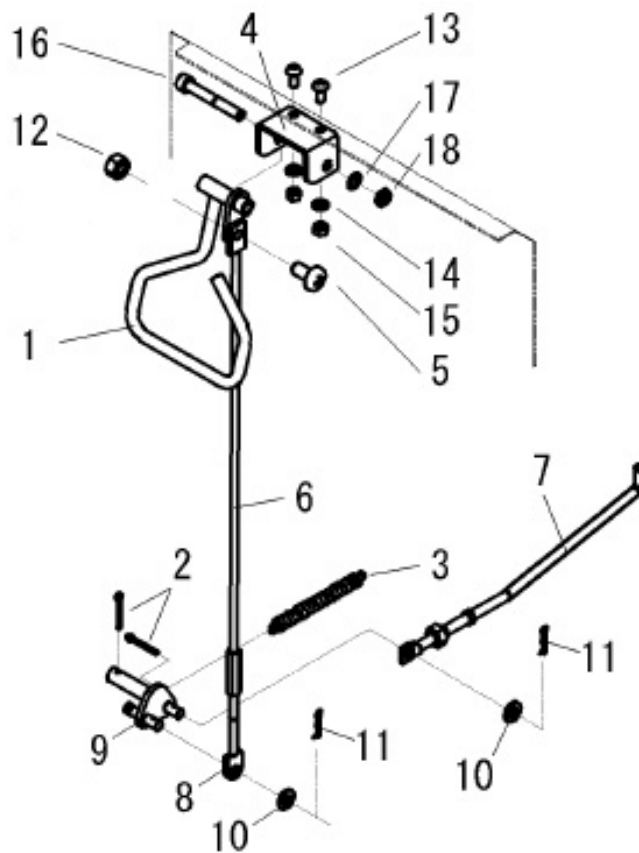

Fig. N1-8

Release Lever Ass'y

Item No	Description	Qty	UDL-250	UDA-500	UDA-800	UDA-350W
N1-9	Jack Pedal Assy	1				
-1	Pedal, Jack	1	UND430010	UND430010	UND430010	UND430010
-2	Pin, Split Nut, Castle	1	0360630	0360630	0360630	0360630
		1	0811652	0811652	0811652	0811652
-3	Shaft (Bolt)	1	0111675-17	0111675-17	0111675-17	0111675-17
-4	Receiver, Pedal	1	NB440012	ND440012	ND440012	ND440012
-5	Pin "R"	1	0340808	0340808	0340808	0340808
-6	Pin, Split Washer	2	0362520	0362520	0362520	0362520
		2	0910812	0910812	0910812	0910812
-7	Pin-1	2	ND420040	ND420040	ND420040	ND420040
-8	Connecting Rod Bush	1	NB421012	NB421012	NB421012	NC421012
		2	ND410070	ND410070	ND410070	ND410070
-9	Screw, Retaining	1	0212410	0212410	0212410	0212410
-10	Shaft for Lever	1	ND140061	ND140061	ND140061	ND140061
-11	Lever, Jack	1	NB410011	ND410011	ND410011	ND410011
-12	Pin-2 Ring Retaining "E"	1	ND410091	ND410091	ND410091	ND410091
		1	0320605	0320605	0320605	0320605
-13	Roller	1	ND410060	ND410060	ND410060	ND410060
-14	Grease Nipple Washer	2	0040600	0040600	0040600	0040600
		2	0910612	0910612	0910612	0910612

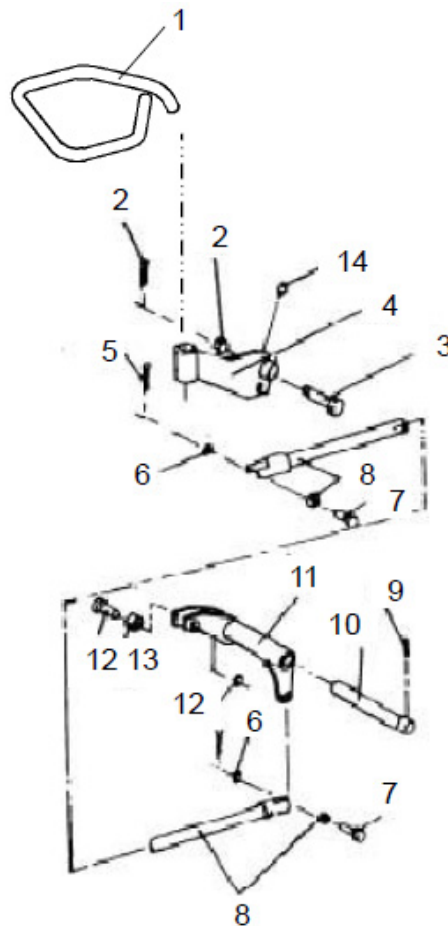

Fig. N1-9

Jack Pedal Ass'y

Item No	Description	Qty	UDL-150
S-1	Platform	1	
-1	Platform Plate	1	NA201012
-2	Screw & Nut Washer, Spring	4 4	0218825 0980853
-3	Plastic Fitting for Stay	2	ND391032

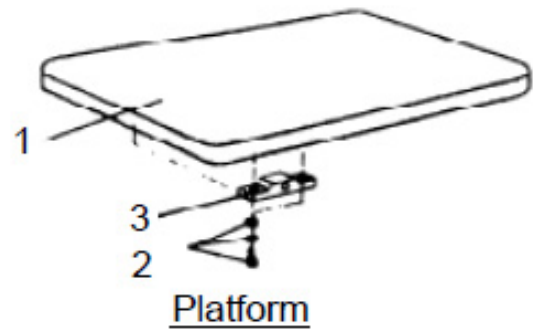

Fig. S-1

Item No	Description	Qty	UDL-150
S-2	Scissor Device	1	
-1-1	Scissor (Outside) (Inside) Pin, Pivot	1 1	(NA320012) (NA310012) NA370002
-1-2	Lift Box Pin, Retaining Shaft Washer	1 2 2 2	NA340012 0321601 NA381002 0911615
-2	Roller (Upper) (Lower)	4 4	NA351002 NA361002
-3	Washer	2	0910812
-4	Stay	2	ND391012
-5	Jack Plate Screw	1 1	NA340052 0218825

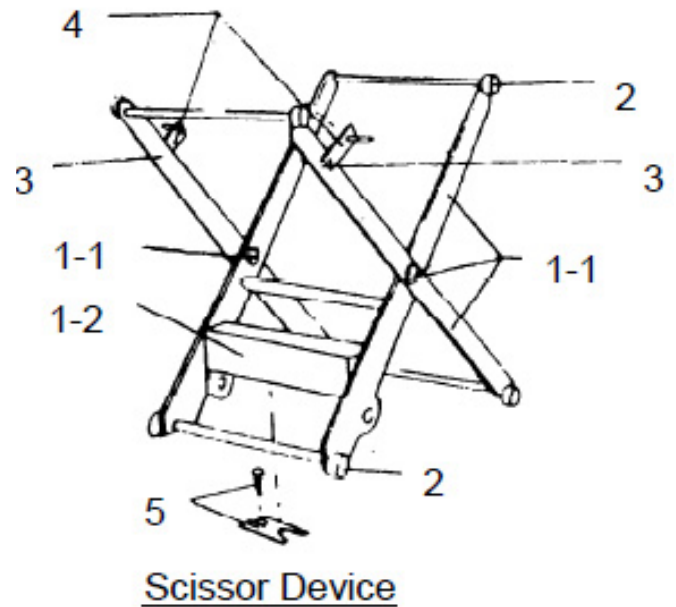
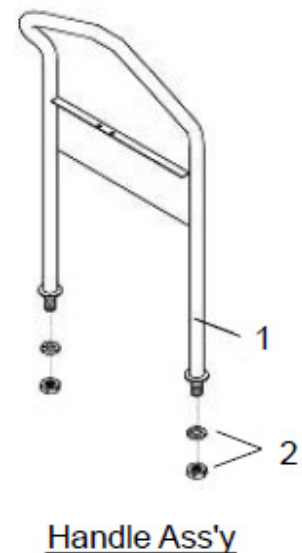

Fig. S-2

Item No	Description	Qty	UDL-150
S-3	Frame (Not illustrated)	1	NA100002

Item No	Description	Qty	UDL-150
S-4	Handle Assy	1	
-1	Handle with name plate	1	NA221012
-2	Nut Washer, Spring	2 2	0812011 0982057

Fig. S-4



Item No	Description	Qty	UDL-150
S-5	Jack Assy	1	*(NA511AA3)
-1	Piston	1	NA510022
-2	Spring, Compression	1	NA531003
-3	Cap Pin, Spring	1	NA540012 0460832
-4	Nut "U" Connecting Rod-3	2 1	0810881 ND741010
*-5	Bolt Nut Washer, Spring	2 2 2	0110825 0810811 0980853
-6	Jack	1	NA510002

\*NA511AA3 does not include S-5-5 bolt, nut and washer.

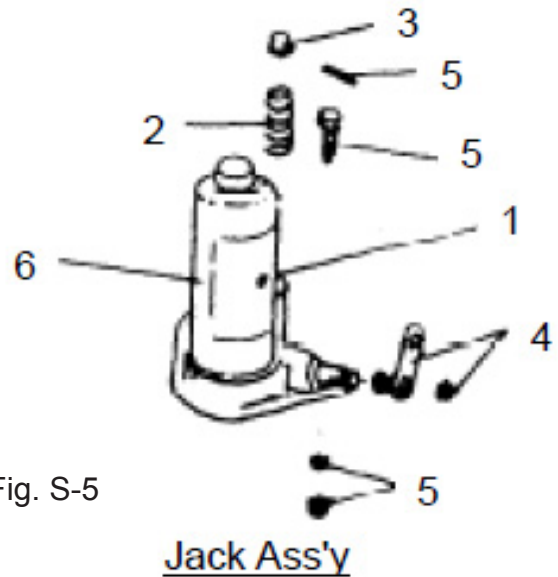
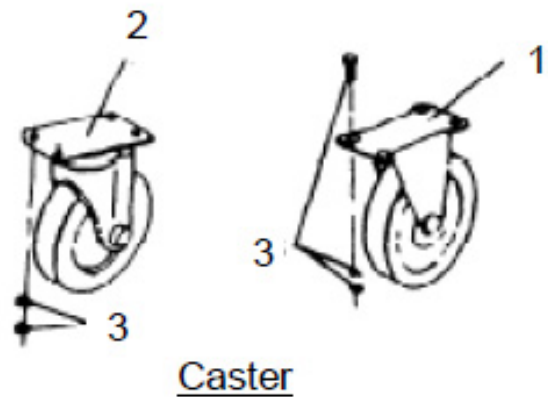

Fig. S-5

Item No	Description	Qty	UDL-150
S-6	Caster	1	
-1	Front Caster	2	K-SKK-R100
-2	Rear Caster	2	J-SKK-R100
-3	Bolt Washer, Spring Nut	16 16 16	 0980865 0810811

Fig. S-6



Item No	Description	Qty	UDL-150
S-7	Parking Lock	1	
-1	Floor Lock	1	NA810002
-2	Bolt	4	0110820
-3	Washer, Spring	4	0980853
-4	Nut	4	0810811

Fig. S-7

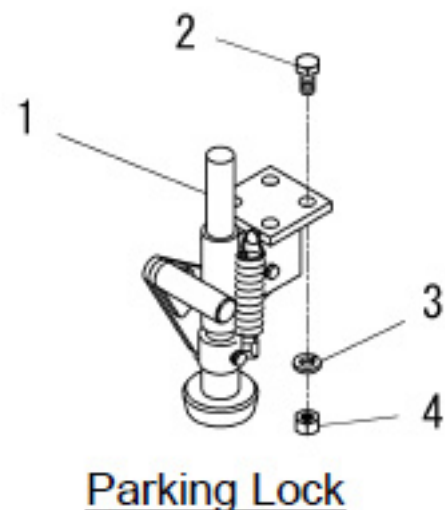

Item No	Description	Qty	UDL-150
S-8	Release Lever Assy	1	
-1	Release Lever	2	UND220100
-2	Pin, Spring	2	0460422
-3	Spring	2	NB760000
-4	Fixed Support	1	UND720010
-5	Screw	1	0210816
-6	Release Lever Rod	1	UND461B1S
-7	Connecting Rod	1	UNA740061
-8	Release Rod	1	UNA461A04
-9	Crank	1	UND740031
-10	Washer	1	0910813
-11	Pin, "R"	1	0340808
-12	Nut "U"	2	0810882
-13	Screw	1	0216616
-14	Washer, Spring	2	0980652
-15	Nut	2	0810611
-16	Bolt	1	0110865
-17	Washer, Spring	1	0910813
-18	Nut	1	0810812

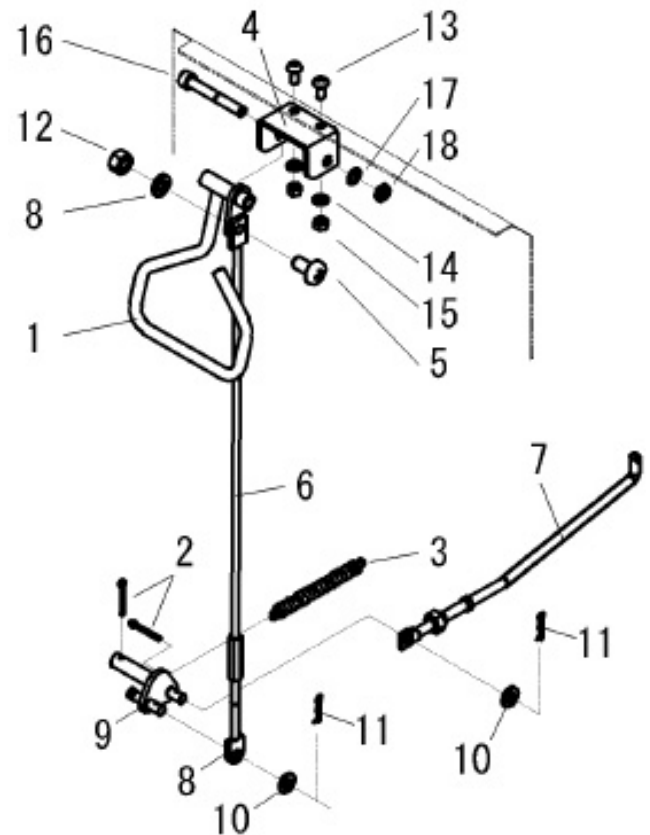

Fig. S-8

Release Lever Ass'y

Item No	Description	Qty	UDL-150
S-9	Jack Pedal Assy	1	
-1	Pedal, Jack	1	UNA430013
-2	Lever, Jack	1	NA401010
-3	Ring, Retaining "C"	1	0321601
-4	Shaft for Lever	1	NA410082
-5	Pin	1	NA410091
-6	Ring Retaining "E"	1	0320625
-6	Roller	1	ND410060

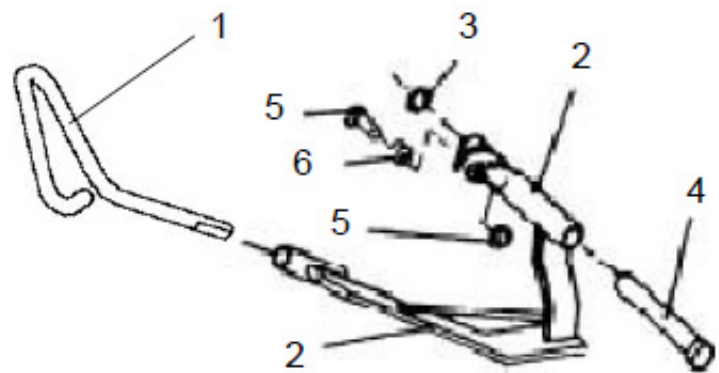

Fig. S-9

Jack Pedal Ass'y

The parts, components, those specifications and quantity may change without notice.

When place of parts order, please refer to respective serial number assigned on brass plate attached on each unit.

# Ordering Replacement Parts

Southworth has carefully chosen the components in your unit to be the best available for the purpose. Replacement parts should be identical to the original equipment. Southworth will not be responsible for equipment failures resulting from the use of incorrect replacement parts or from unauthorized modifications to the unit.

Southworth can supply all replacement parts for your Dandy Lift. With your order, please include the model number and the serial number of the unit. You can find these numbers on the name plate. This plate is located within the scissors mechanism.

To order replacement parts, please call the Parts Department at (207) 878-0700 or (800) 743-1000. Parts are shipped subject to the following terms:

- FOB factory
- Returns only with the approval of our Parts Department.
- Payment net 30 days (except parts covered by warranty).
- Freight collect (except parts covered by warranty).

Parts replaced under warranty are on a "charge-credit" basis. We will invoice you when we ship the replacement part, then credit you when you return the worn or damaged part.

Parts Department  
Southworth Products Corp.  
P.O. Box 1380  
Portland, Maine, 04104-1380  
Telephone: (800)743-1000 or (207)878-0700  
FAX: (207)797-4734  
Service@SouthworthProducts.com

## 2 YEAR WARRANTY

Southworth Products Corp warrants this product to be free from defects in material or workmanship for a period of **2 years** of single shift usage from date of shipment, providing claim is made in writing within that time period. This warranty shall not cover modified designs for special applications, failure or defective operation caused by misuse, misapplication, negligence or accident, exceeding recommended capacities, failure to perform required maintenance or altering or repairing, unless alteration is authorized by Southworth Products Corp. Except as set forth herein, there are no other warranties, express or implied, including the warranties of merchantability and fitness for a particular purpose, all of which are hereby excluded.

Southworth Products Corp makes no warranty or representation with respect to the compliance of any product with state or local safety or product standard codes, and any failure to comply with such codes shall not be considered a defect of material or workmanship under this warranty. Southworth Products Corp shall not be liable for any direct or consequential damages arising out of such noncompliance.

Southworth Products Corp's obligation under this warranty is limited to the replacement or repair of defective components at its factory or another location at Southworth Products Corp's discretion. This is buyer's sole remedy. Except as stated herein, Southworth Products Corp will not be liable for any loss, injury or damage to persons or property, nor for direct, indirect, or consequential damage of any kind, resulting from failure or defective operation of said product.

This warranty may be altered only in writing by Southworth Products Corp, Portland, Maine.

**SOUTHWORTH**

**SOUTHWORTH PRODUCTS CORP**  
P.O. Box 1380, Portland, ME 04104-1380  
Telephone: (800) 743-1000 • (207) 878-0700  
Fax: (207) 797-4734  
[www.SouthworthProducts.com](http://www.SouthworthProducts.com)

# **SOUTHWORTH**

**making work faster, safer, and easier**

Southworth is the world class supplier of products designed to improve productivity and enhance safety. Our staff has over 400 years of engineering experience. If one of our standard products does not meet your needs, our engineers can custom design equipment specifically suited to your material handling application.



**Spring PalletPal Load Leveler**



**Lift with Flush Mount Turntable**



**Portable Container Tilters**



**Dock Lifts**



**Roll on Level Loaders**



**Portable Lifts**



**Stretchwrapping**



**Positioning**

**Floor to Mezzanine Lifts**



**Pallet Rotators**



**For more information, contact Southworth Products**

Telephone (800) 743-1000 Fax (207) 797-4734

**Email: [salesinfo@SouthworthProducts.com](mailto:salesinfo@SouthworthProducts.com)**