

SOUTHWORTH

OWNER'S MANUAL

Low Profile Lifts

(This manual is for machines manufactured
in May 2013 and newer)

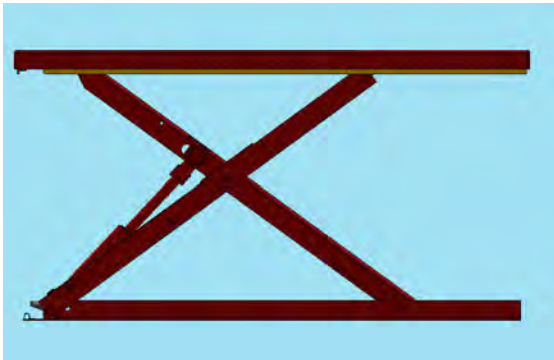

LiftMat



Roll-E

Model # _____

Serial # _____

Placed in Service _____

SOUTHWORTH PRODUCTS CORP

P.O. Box 1380, Portland, Maine 04104-1380

Phone (800) 743-1000 • (207) 878-0700 • Fax (207) 797-4734

www.SouthworthProducts.com

E-mail: service@SouthworthProducts.com

May 2013

Southworth Products Corp is widely acknowledged as the leading maker of hydraulic lifts and materials-handling equipment. Southworth machines are rugged and reliable, and are designed to provide years of trouble-free service. The designs are based on extensive engineering experience. These are good reasons for specifying Southworth machines in your plant.

Contents

INTRODUCTION	Page 4
RESPONSIBILITY OF OWNERS AND USERS	5
SAFETY	6
Safety Regulations/Requirements	6
Safe Servicing of the lift	6
INSTALLATION INSTRUCTIONS	7
Preparation	7
Assembly	7
Hydraulic Oil Specifications	7
OPERATING INSTRUCTIONS.....	11
Safety Label Compliance.....	12
MAINTENANCE	14
Hazards	14
Routine Periodic Maintenance.....	14
Repacking Cylinders.....	16
Replacing Leg Rollers.....	17
Troubleshooting Warning and Check List	18
ORDERING REPLACEMENT PARTS.....	19
WARRANTY	Back of Manual

List of Figures

Figure 1 Engaging Maintenance Chocks.....	6
Figure 2 Hydraulic Schematic	8
Figure 3 Wiring Diagram for Junction Box.....	9
Figure 4 Electrical Diagram	9
Figure 5 Hydraulic Power Unit.....	10
Figure 6 Safe Loading and Unloading	11
Figure 7 Labels and Precautionary Markings	13
Figure 8 Hydraulic Cylinder	16

Introduction

This manual contains information to acquaint you with the safe and proper installation, use, and upkeep of the machine. You should ensure that this manual is available to personnel working with the machine and require its use by these personnel.

In the interest of safety, please read this entire manual carefully, and be familiar with its contents before you install, use, or service the machine. If you have any questions about any instructions in this manual, please contact your dealer or Southworth Products Corporation.

Southworth's product warranty is provided in the back of this manual. This instruction manual is **not intended to be or to create any other warranty, expressed or implied, including any implied warranty of merchantability or fitness for a particular purpose, all of which are hereby expressly excluded.**

As set forth more specifically in the product warranty. Southworth's obligation under that warranty is **limited** to the repair or replacement of defective components, which shall be the buyer's **sole remedy. Southworth shall not be liable for any loss, injury, or damage to persons or property, nor for any direct, indirect, or consequential damage of any kind resulting from the lift table.**

Responsibility of Owners and Users

Inspection and Maintenance

The device shall be inspected and maintained in proper working order in accordance with Southworth's owner's manual.

Removal from Service

Any device not in safe operating condition such as, but not limited to, excessive leakage, missing rollers, pins, or fasteners, any bent or cracked structural members, cut or frayed electric, hydraulic, or pneumatic lines, damaged or malfunctioning controls or safety devices, etc. shall be removed from service until it is repaired to the original manufacturer's standards.

Deflection

It is the responsibility of the user/purchaser to advise the manufacturer where deflection may be critical to the application.

Repairs

All repairs shall be made by qualified personnel in conformance with Southworth's instructions.

Operators

Only trained personnel and authorized personnel shall be permitted to operate the lift.

Before Operation

Before using the device, the operator shall have:

- Read and/or had explained, and understood, the manufacturer's operating instructions and safety rules.
- Inspected the device for proper operation and condition. Any suspect item shall be carefully examined and a determination made by a qualified person as to whether it constitutes a hazard. All items not in conformance with Southworth's specification shall be corrected before further use of the equipment.

During Operation

The device shall only be used in accordance with this owner's manual.

- Do not overload.
- Ensure that all safety devices are operational and in place.

Modifications or Alterations

Modifications or alterations to any Southworth industrial positioning equipment shall be made only with written permission from Southworth.

Safety Regulations/Requirements

There is a built-in safety function in the safety frame. If the safety frame is touched on its way down, the table stops immediately. To continue lowering, the table has to be raised a little to be able to lower again.

The lift tables are always delivered with a control unit of the “deadman” type, which means that when the up or down button (or foot pedal on a footswitch control) is released the table will stop immediately.

Employee and employer must ensure that risk of trapping does not occur during installation use or maintenance of the lifting equipment.

1. Do not exceed the lifting capacity.
2. Check the action of the safety frames and the distance around the equipment to eliminate the risk trapping.
3. Precautionary labeling must be legible.
4. Check for damage due to overloading.
5. Check and maintain electric cables and hoses.
6. Check for oil leakage.
7. Ensure there is no debris under the lift.
8. When the load is traveling up or down the load should be evenly distributed.
9. Hazard – no hands or feet should ever be under the platform.

Safe Servicing of the lift



Only authorized personnel should perform inspection or maintenance and service procedures. Unauthorized personnel attempting these procedures do so at the risk of severe injury or death.



Failure to properly adhere to lift blocking procedures is to risk the sudden and uncontrolled descent of the lift during maintenance or inspection. A falling lift can cause severe injury or death.

This procedure describes the only factory-approved method of working under a lift. Follow these instructions **EVERY** time you plan to reach or crawl beneath the lift to perform service or maintenance – no matter how momentary that might be.

If the factory-provided maintenance device is damaged or missing, stop immediately and consult the factory for assistance. Southworth is not liable for your failure to use the approved maintenance devices and procedures that have been provided.

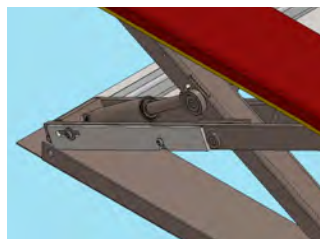

Maintenance Chock Disengaged (stored position)



Maintenance Chock Engaged

Figure 1: Engaging Maintenance Chocks

1. Any load must be removed from the lift prior to engaging the maintenance devices. These devices are designed to support an unloaded lift only. Failure to remove the load from the lift prior to blocking could cause the failure of the maintenance device(s) and allow the lift to fall unexpectedly.
2. Raise the lift to its fully raised position. If you do not, the maintenance device(s) may not be able to be placed properly in their designed engaged position.

3. Rotate the maintenance devices from their stored location and place them into the engaged position as shown in Figure 1.
4. Lower the lift until it makes complete contact with the maintenance devices. Re-check to ensure that both devices are fully and securely engaged.

⚠ DANGER

If for any reason you are unable to lower the lift completely onto the maintenance device(s), stop immediately and consult the factory. Failure to properly use the factory approved maintenance devices could result in severe injury or death.

Installation Instructions

Preparation

Before you start to use the unit, check for local codes and ordinances which may apply. It is your responsibility to obtain any necessary permits.

Read all of these installation instructions carefully. Be sure to read and understand all of the warnings.

The unit should only be used indoors, or it should be protected from the weather.

NOTICE

DO NOT PULL THIS LIFT OPEN. This will damage the lift cylinders. This lift must be raised by the hydraulic power unit.

⚠ DANGER

The AC-powered unit has parts which carry 115 volts or more. This voltage can kill you! Don't work with the electrical parts unless you are a qualified electrician.

⚠ WARNING

Protect the unit from rain or moisture. If the electrical parts in the power unit get wet, workers may be hurt by electrical shock. The electrical parts may fail if they are wet.

⚠ CAUTION

This unit has an electric motor that can create sparks. Don't use the unit in an area where flammable gases may be present.

Remove the shipping material and remove the unit from the skid. You will need a crane or lift truck that can lift the unit safely.

NOTICE

Do not try to move the lift by supporting the tilt platform. One end of the tilt platform is free.

On the front of this manual, write down the model number, serial number, and date the unit is placed in service. The location of the name plate is up under the platform.

Assembly

1. The lift must always be securely fixed to the floor with expander bolt or anchors.
2. Run the lift to its upper position and engage the maintenance device on both sides.
3. Lower the lift onto to maintenance device.
4. An electrician must make the installation of the electrical system if three phase.
5. Test the function of the safety frame on all sides.
6. Ensure the load is evenly distributed load.
7. The push button or foot switch should be installed to have a good view when the lift is moving.

Figure 2 Hydraulic Schematic

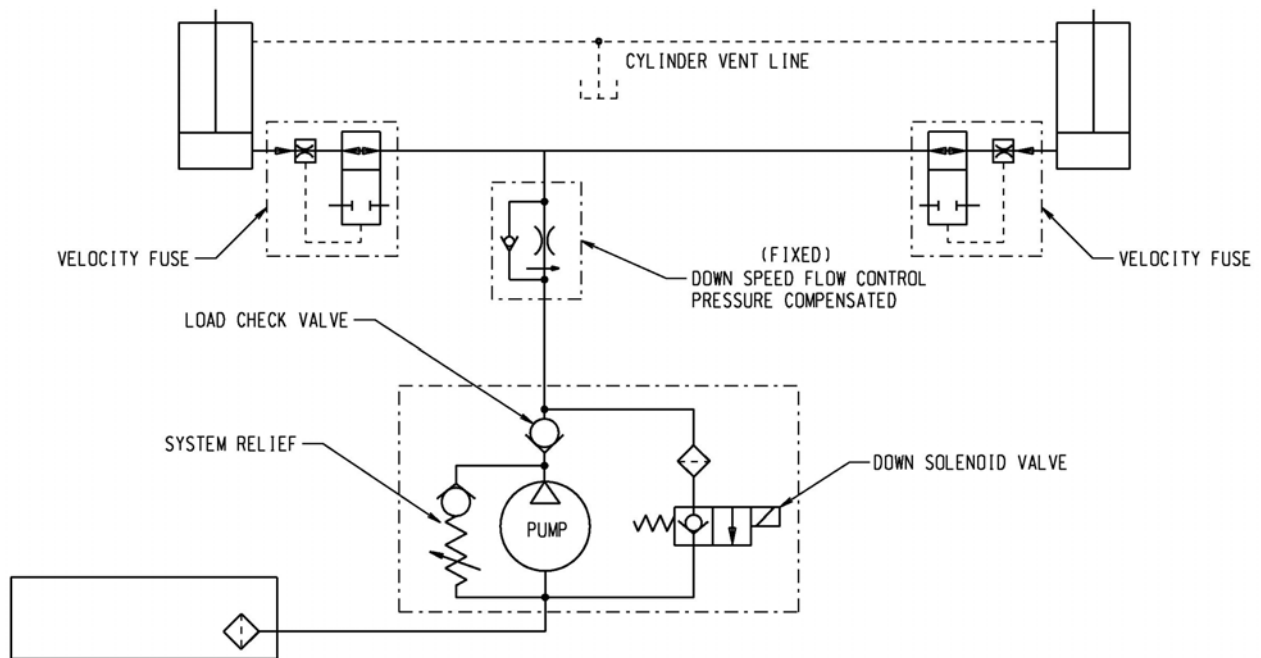

Hydraulic Oil Specifications

If the lift will be used at normal ambient temperatures, Southworth supplies the unit with Citgo AW 32 oil. This may be replaced by any other good quality oil with 150 SSU at 100° F and rust and oxidation inhibitors and anti-wear properties.

If the lift will be used at ambient temperatures below 0°F, use aircraft hydraulic oil. Use Type 15 aircraft hydraulic oil.

The following are equivalent to CITGO AW32:

TYPE	MANUFACTURER
DTE 24	EXXON/MOBIL
NUTO H32	EXXON/MOBIL
AMOCO AW32	CHEVRON (AMOCO CO.)

NOTICE

It is very important to keep the hydraulic oil free of dirt, dust, metal chips, water, and other con-tamination. Most of the problems with hydraulic systems are caused by contamination in the oil.

Figure 3 Wiring Diagram for Junction Box

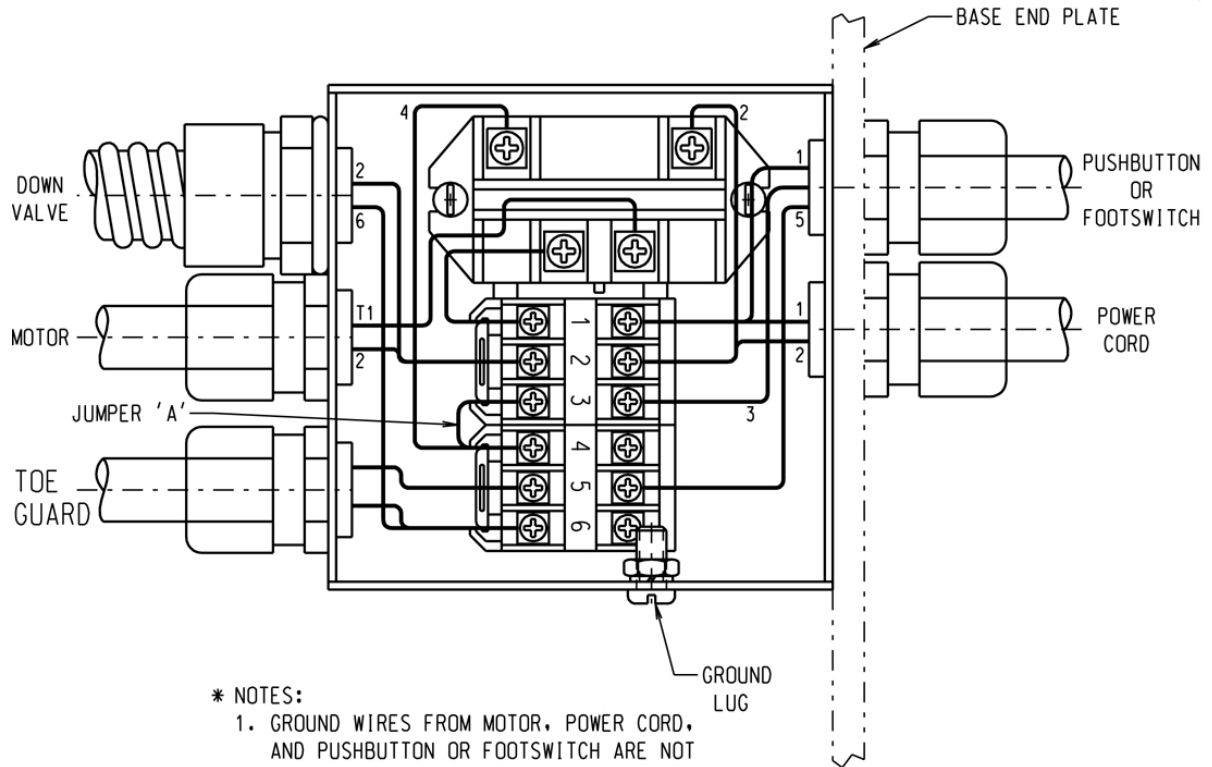

* NOTES:

1. GROUND WIRES FROM MOTOR, POWER CORD, AND PUSHBUTTON OR FOOTSWITCH ARE NOT SHOWN FOR CLARITY. ATTACH ALL GROUND WIRES TO THE ENCLOSURE GROUND LUG.
2. ENTRY LOCATIONS OF ELECTRICAL FITTINGS MAY DIFFER FROM THOSE SHOWN.

Figure 4 Electrical Diagram

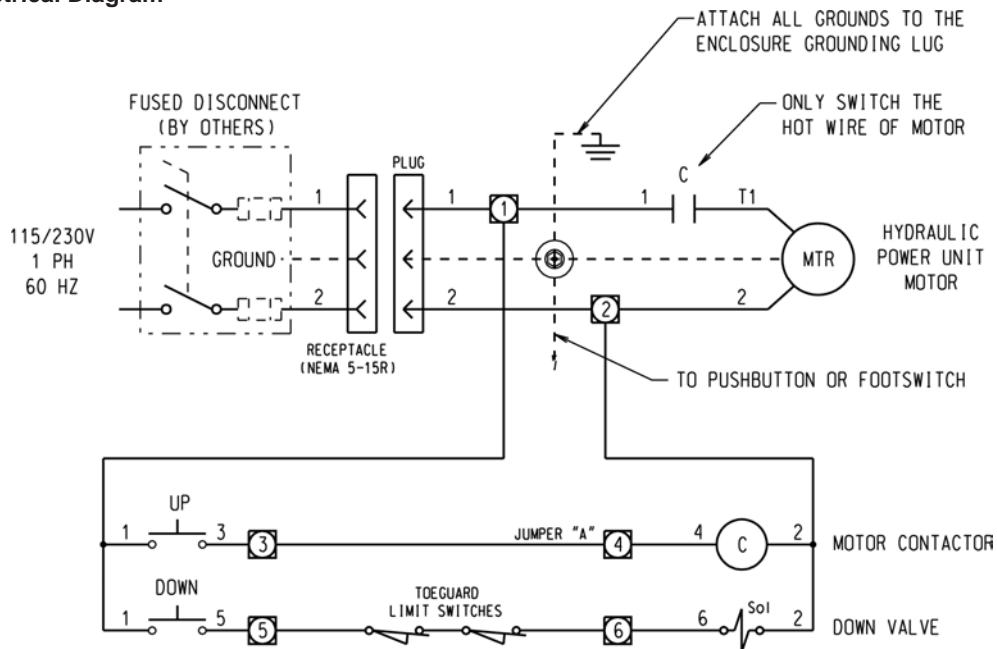

NOTE: WIRE TO THE N.O. CONTACTS OF THE TOEGUARD LIMIT SWITCHES. UNDER NORMAL OPERATING CIRCUMSTANCES THE CONTACTS WILL BE HELD CLOSED BY THE MECHANICAL TOEGUARD.

Roll-E

Figure 5 Hydraulic Power Unit

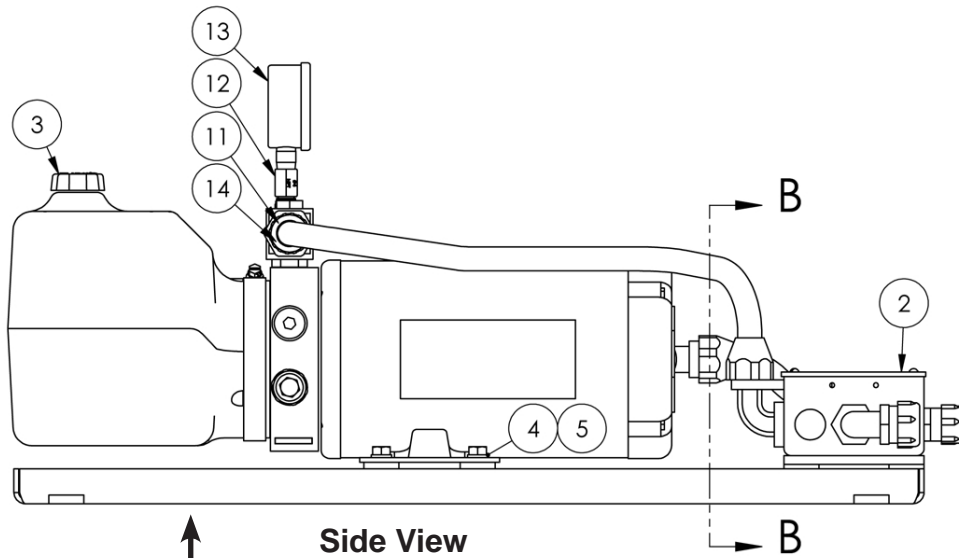
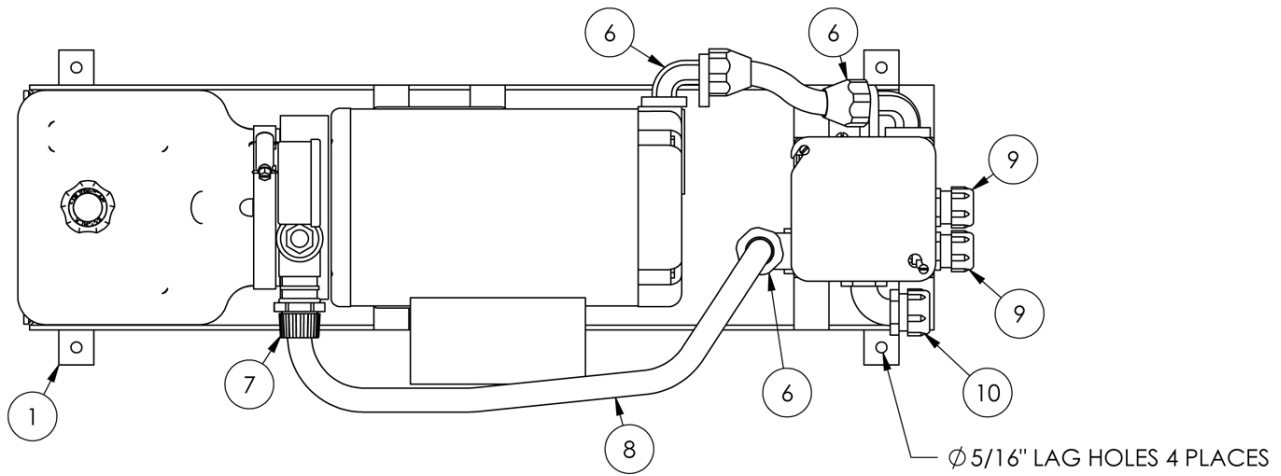

Side View

Mounting
Plate

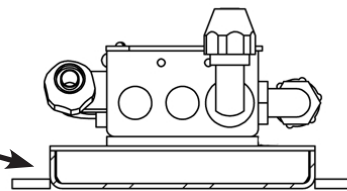

SECTION B-B
End View

NOTE: Some hydraulic power units may be provided without lag plates. For lagging power unit down or mounting to a wall contact the service department for an option bracket. 800-743-1000

OPERATING INSTRUCTIONS

1. Before operating the lift, read and understand this entire section.

⚠ DANGER

The lift may use a power supply of up to 575 Volts AC. This voltage can kill. Do not work with the electrical parts unless you are a qualified electrician!

2. Locate the lift on a firm, flat surface as shown in Figure 6. Stationary lifts should be lagged to the floor.

⚠ WARNING

If you place the lift on a soft surface, it may tip over, especially when it is loaded or raised. Someone may be hurt, and the lift and load may be damaged.

3. Load the lift correctly.

Be sure that the load weighs no more than the maximum rated for the lift. The maximum rated load is shown on the platform skirt.

Be sure the load is centered and stable. The load on this lift must be evenly distributed.

⚠ WARNING

Do not try to lift a load that exceeds the maximum rating. If you try this, the lift may fail suddenly. Someone may be hurt, and the lift and load may be damaged.

Do not try to load the lift while the lift is moving.

4. Be sure all workers are clear of the lift. Remove any lumber or other material which may fall onto the lift.

⚠ WARNING

As the lift moves up and down, “pinch points” are created. Stay away from these pinch points! Part of your body or clothing may become caught, and you may be hurt.

5. To operate the lift., press and hold the “up” button to raise the lift, and “down” to lower it. If the lift does not operate right away, turn off the lift and call a qualified maintenance worker. If you hear a squealing noise from the pump, the pressure relief valve is operating. Do not continue to use the lift! The pump will overheat very quickly, and may be permanently damaged. The relief valve is included to protect the machine operators – do not change the relief pressure setting.

6. Wait until the lift table has stopped. Unload the lift.

NOTICE

The warning labels on the lift are there for your safety. If you find that the labels are worn or missing, or have been painted over, ask Maintenance to replace the labels before you use the lift.

Figure 6 Safe Loading and Unloading

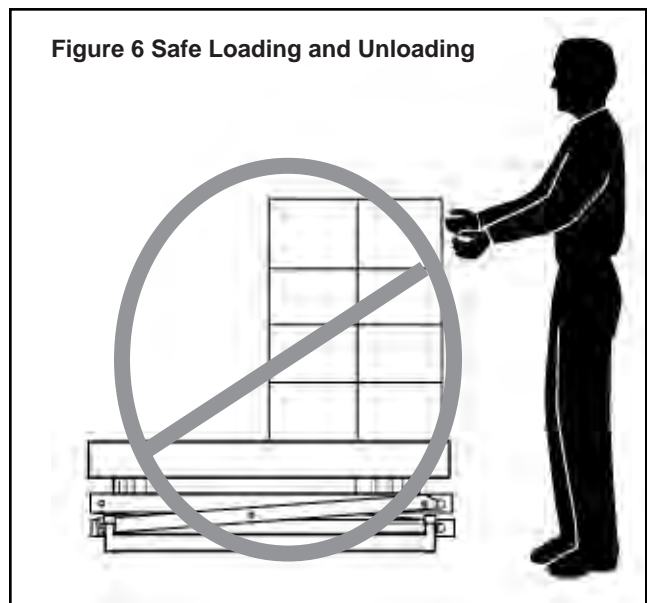

⚠ WARNING

Ensure that loading and unloading of the lift is done in even layers. Loading or unloading a load on one side may cause the load to tip over and you may be injured. This can also damage the unit.

SAFETY LABEL COMPLIANCE

To aid in understanding the concept and the importance of the symbol and signal word, the following has been excerpted from ANSI Z535.4.

4.10 Safety Alert Symbols

A symbol which indicates a potential personal injury hazard. It is composed of an equilateral triangle surrounding an exclamation mark. The safety alert symbol shall not be used to alert persons to property-damage-only accidents.



For use with DANGER signal word
(Red Background)



For use with WARNING signal word
(Orange Background)



For use with CAUTION signal word
(Yellow Background)

4.1 Signal Words

The meaning of different signal words as defined by ANSI Z535.6 and Z535.4 standards may be provided in collateral materials. The following artwork may be used for this purpose.



(Red Background)

DANGER indicates a hazardous situation which, if not avoided, will result in death or serious injury.



(Orange Background)

WARNING indicates a hazardous situation which, if not avoided, could result in death or serious injury.



(Yellow Background)

CAUTION, used with the safety alert symbol, indicates a hazardous situation which, if not avoided, could result in minor or moderate injury.



(Blue Background)

NOTICE is used to address practices not related to personal injury.

LOCATE ITEM NO. 5904642 ON BOTH SIDES OF LIFT PLATFORM AS SHOWN.



LOCATE ITEM NO. 2998353 ON PLATFORM SIDES AS SHOWN.



ALWAYS USE BOTH MAINTENANCE DEVICES WHEN PERFORMING MAINTENANCE

LOCATE ITEM NO. 10003945 FACING AS SHOWN ON MAINTENANCE CHECK ON BOTH SIDES OF BASE.

FOR MAINTENANCE ONLY

LOCATE ITEM NO. 2991184 FACING AS SHOWN ON MAINTENANCE CHECK ON BOTH SIDES OF BASE.

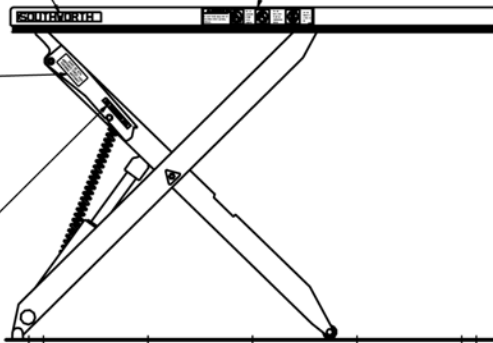

LOCATE CAPACITY DECALS ON PLATFORM ENDS. TWO PER END. AS SHOWN. SEE BLOCK "A"

CAPACITY 2200 LBS

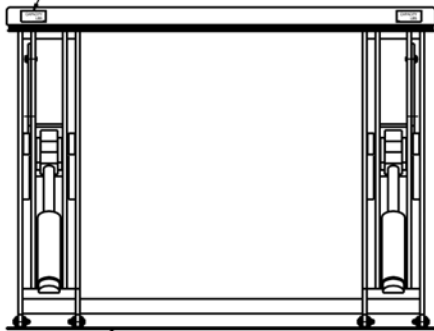

LOCATE POWER DECAL ON JUNCTION BOX AS SHOWN. SEE BLOCK "B"

POWER 115 VOLTS 1 PHASE

CONTROL 24 VOLTS 1 PHASE

LOCATE CONTROL DECAL ON JUNCTION BOX AS SHOWN. SEE BLOCK "C"

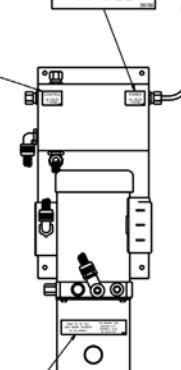

FASTEN ITEM NO. 2991183 TO POWER UNIT

NOTICE
FASTEN ITEM NO. 2998365 TO POWER UNIT



LOCATE ITEM NO. 2986737 ON LIFT BASE PLATE AS SHOWN.

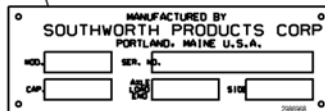

LOCATE ITEM NO. 2986968 ON TORQUE TUBE BETWEEN LEGS AND A SECOND SERIAL NAME PLATE ON UNDERSIDE OF PLATFORM

TANK TO BE FULL ONLY WHEN CYLINDER IS COLLAPSED
THIS MACHINE USES DEXTRON 3 ATF HYDRAULIC FLUID OR EQUIVALENT

LOCATE ITEM NO. 2991182 ON HYDRAULIC TANK AS SHOWN.

Figure 7 Labels and Precautionary Markings

MAINTENANCE

All servicing should be done by qualified personnel. Qualified personnel should be able to read and understand wiring and hydraulic diagrams. They should be able to troubleshoot live electrical circuits safely and in accordance with accepted practice. **For safety's sake**, if in doubt, please contact your dealer or Southworth's Customer Service Department at (207) 878-0700 or (800) 743-1000. Before servicing the lift, read and understand this entire section and the section entitled "Operating Instructions."

Hazards

There are several hazards you should be aware of as you service the lift:

⚠ DANGER

The lift may use a power supply of up to 575 Volts AC. This voltage can kill. Do not work with the electrical parts unless you are a qualified electrician!

⚠ WARNING

- As the lift moves up and down, "pinch points". Keep hands, feet, and loose clothing away from these pinch points. If your hand or arm or a part of your clothing is caught, you may be hurt.

- A falling lift can cause severe personal injury. Before working under the lift, raise the lift and insert the maintenance devices, as shown in Figure 1. Do this every time you work under the lift!

⚠ WARNING

- Do not change the setting on the relief valve. If you do change the setting, this may cause a hydraulic part to fail. The lift may drop suddenly. Someone may be hurt, and the lift and the load may be damaged. The hydraulic parts in the lift are designed to handle a certain amount of pressure. The relief valve is set to relieve this pressure before it becomes too great. The relief valve has been included for the protection of all of the workers who use the lift.

- Release of fluids under high pressure can cause personal injury. Before you open any part of the hydraulic system, be sure to release the hydraulic pressure.

- The warning labels on the lift are there for the safety of the operators. See Figure 7. If the labels are worn or missing, or have been painted over, replace them before releasing the lift for operation.

Routine Periodic Maintenance

Every month:

- Visually inspect the leg rollers, center pivot bushings and pins, cylinder clevis pins and bushings, and the leg hinge pins and bushings for signs of wear. Contact Southworth for instructions for repair of the center pivot pins and bushings.

⚠ WARNING

If you are going to repair the center pivot pins and bushings, you must support the lift table in a special way. Each set of leg plates, on both sides of the unit, must be clamped together firmly, using large C-clamps. You cannot use the maintenance devices shown in Figure 1 – with the pivot pins removed, they will not support the table top. If you do not support the lift table correctly, the top may drop suddenly when you remove the pivot pins. Please contact Southworth for instructions.

- Apply oil or WD-40 to the parts listed in the last step.

NOTE: Although the bearings are "lifetime lubricated" their performance may be extended by additional periodic lubrication.

- Check the level and appearance of the hydraulic fluid. First, **raise the lift and insert the maintenance devices, as shown in Figure 1**. On most models, when the lift is fully elevated, the oil should be about 3/4 inch above the bottom of the tank. Use a dipstick to check the oil level, and add oil as necessary. Change the oil if it has darkened, or feels gritty or sticky.

NOTICE

It is important to use hydraulic fluid with the correct grade and properties. See the hydraulic oil specification in this manual, Page 8.

Every six months or 500 hours of operation, whichever comes first:

- **Raise the lift and insert the maintenance devices, as shown in Figure 1.**
- Check all of the hydraulic fittings and hoses, and repair the connections as necessary. Occasionally the fittings can be worked loose by the vibrations from the power unit.

WARNING

If a hydraulic fitting becomes loose, or if a hydraulic hose breaks, the hydraulic fluid may escape from the system under pressure. If the lift is raised when this happens, it can drop quickly. Someone may be hurt, or the lift or load may be damaged.

- The clear plastic vent line and the cylinder rod(s) should be free of hydraulic fluid. If you find much fluid in either place, the cylinder seals may be leaking. (It is also possible the tank may be overfilled.) See the section on “Repacking Southworth Cylinders.”
- Disassemble the down valve. Blow the valve plunger clean with compressed air. Reassemble and reinstall.
- Drain and discard the hydraulic fluid. The suction filter is in the tank, at the point where the suction line runs out to the pump. Unscrew the hydraulic filter.
- Blow the filter clean. Reinstall the filter in the tank and reassemble the hydraulic line.
- Refill the tank with new hydraulic fluid.

NOTICE

If you continue to use fluid after it has “worn out,” the moving parts in the system will wear more quickly.

- Be sure all of the warning labels are in position and legible. The labels are shown in Figure 7. The warning labels are intended to protect your workers. If the labels are missing, or if they have been painted over, replace them.

Figure 8 – H-Style Cylinder

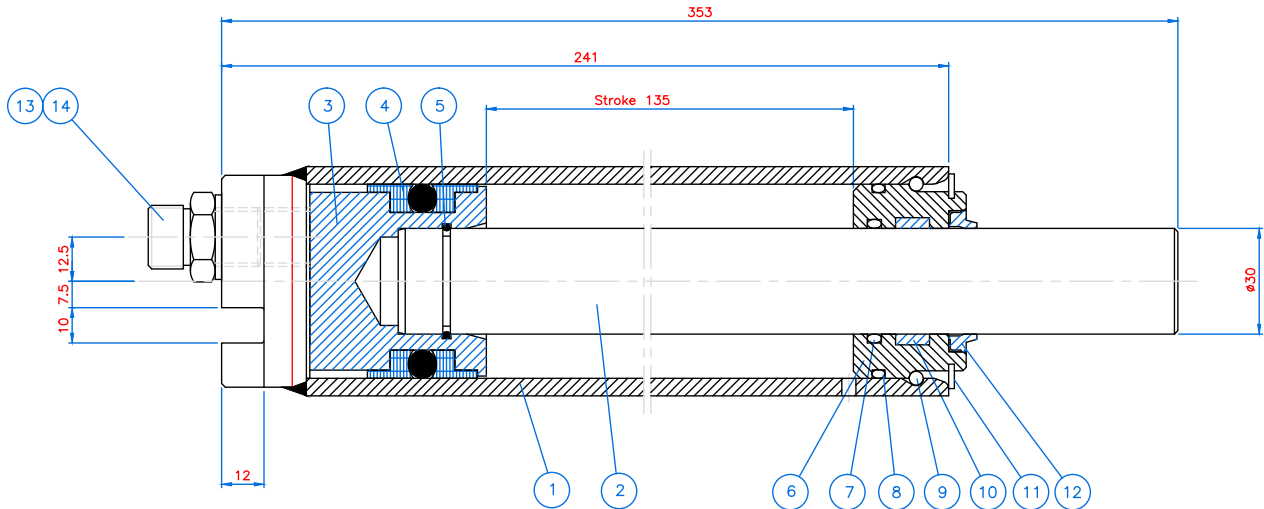

Item	Description	Item	Description
1	Cylinder Barrel	8	O-Ring
2	Piston Rod	9	Retaining Ring
3	Piston	10	Wear Ring
4	Seal	11	Ring
5	Locking Ring	12	Wiper
6	Rod Bearing	13	Hose Burst Valve
7	O-Ring	14	Fitting

HC 55/30-135
Hydraulic Cylinder Assembly

Repacking Cylinders

This section will tell you how to repack an “H-style” cylinder, shown in Figure 8. This type of cylinder is exclusive to Southworth, and repacking kits are only available through Southworth. To order a repacking kit, please call the Parts Department at (207) 878- 0700 or (800) 743-1000. When ordering, specify the model number and serial number of the lift, and the cylinder number(s), as listed on the base of the cylinder(s).

Before beginning this procedure, **read and understand this entire section.**

WARNING

Before working underneath the lift, always raise the lift and insert the maintenance devices, as shown in Figure 1. Failure to do so may result in damage to the lift and severe personal injury!

1. Before you disassemble the old cylinder, be sure you have these items on hand:
 - A repacking kit. Parts may be damaged when you disassemble the cylinder. You should have replacement parts on hand so you can reassemble the lift and use it immediately.
 - A supply of new hydraulic oil. Contaminated oil may damage the new packing.
 - A container to catch the used oil.
 - A clean place to work. Choose a place which will not be damaged if you spill some oil.

2. Raise the lift and insert the maintenance devices, see Figure 1.

3. Turn off electrical power at the main disconnect or circuit breaker, or unplug the machine. This will prevent the lift from moving accidentally while you are working on it.
4. Disconnect the cylinder supply line at the pump, and place the end into a container to collect the used oil.
5. At the top end of the cylinder rod, remove the “keeper,” and drive out the clevis pin. Push the rod back into the cylinder to drive the hydraulic fluid out through the hose into the container. You may use air pressure at the vent hole to do this. Disconnect the hydraulic line(s) from the cylinder(s). Lift the cylinder(s) out of the lift. Be careful the cylinder is heavy!
6. Figure 8 shows the parts inside a lift cylinder. At the upper end of the cylinder, remove the snap ring. Pull the rod and piston all the way out of the cylinder. This assembly is heavy -- be careful not to drop it as it comes free.
7. Remove the press-fit bushing from the hole at the upper end of the cylinder rod.
8. Look for deformation around the hole at the clevis end of the cylinder rod. If necessary, clean up the rod diameter with a file to allow the rod bearing to slide off without damage.
9. Remove the plastic rod bearing from the cylinder rod. Observe how the wiper ring sits in the rod bearing.

Remove the wiper ring and the O-ring from the rod bearing. Do not try to remove the aluminum piston from the cylinder rod, as this will damage the assembly. Remove the poly U-cup and the fiber wear ring from the piston.

10. Check the vent plug, and clean it if it appears dirty.

NOTICE

While reassembling, it is very important to keep all of the parts free of dirt, dust, metal chips, water, and other contamination. Most of the problems with hydraulic systems are caused by contamination in the oil.

11. Clean the piston surfaces, and install a new fiber wear ring. Install a new poly U-cup seal, with the open part of the seal facing down.

12. Clean all of the surfaces on the rod bearing. Install a new O-ring and wiper. Replace the rod bearing assembly on the rod.

NOTICE

Be careful not to install the wiper backwards. The lip on the wiper should point upwards, as shown in the detail in Figure 8.

13. Clean the bore of the cylinder tube thoroughly. Inspect the bore of the tube for scratches that run up and down, along the length of the cylinder. If you do see any scratches, hone the inner surface of the cylinder. Be sure to clean the tube thoroughly after you do this.

14. Lubricate the seal and piston with clean grease or oil. Carefully insert the piston and rod back into the cylinder. Be very careful not to pinch or tear the poly U-cup as the piston passes the shoulder inside the cylinder. It is helpful to tip the rod assembly and twist it as you slide it into the cylinder.

Once the piston is inside the cylinder, it should slide easily.

NOTICE

If the poly U-cup is pinched or torn during reassembly, the piston may not maintain pressure as designed.

15. Slide the rod bearing into the cylinder. Install a new snap ring to hold the rod bearing in place. Replace the bushing or install a new one in the top of the cylinder rod.

16. Install the cylinder in the lift. Replace the clevis pin and "keeper." Reconnect all of the hydraulic lines and the vent line.

17. At the start of the packing process, you drained the cylinder(s) into a container. Replace this used oil with an equal amount of fresh oil. Be sure to reinstall the vent plug when you're done.

18. Turn on the electrical power and press the "up" button. The pump will self-prime. After a few seconds, the cylinder should lift the table off the blocks. Remove the maintenance devices. Cycle the lift up and down a few times to remove air pockets. Check for leaks.

19. Raise the lift and check the oil level with a dipstick. The oil should be about 3/4 inch above the bottom of the tank.

20. If you have spilled any oil, clean it up.

⚠ DANGER

Spilled hydraulic oil is slippery, and may present a fire hazard. Always clean up any spilled oil.

Replacing Leg Rollers

Please contact Customer Service at Southworth Products Corp. for instructions for your model and application at (207) 878-0700 or (800) 743-1000.

TROUBLESHOOTING WARNINGS

All servicing should be done by qualified personnel. Qualified personnel should be able to read and understand wiring and hydraulic diagrams. They should be able to troubleshoot live electrical circuits safely and in accordance with accepted practice. **For safety's sake**, if in doubt, please contact your dealer or Southworth Products Corp.

Before servicing the lift, **read and understand this entire section and the section entitled "Operating Instructions."**



Before working underneath the lift, always raise the lift and insert the maintenance devices, as shown in Figure 1. Failure to do so may result in damage to the lift and severe personal injury!

PROBLEM	POSSIBLE CAUSE	CHECK THIS
Lift will not raise	Weight of load too heavy	Check the actual weight of the load
	Motor not running	Check the main disconnect switch, fuses, and wiring to the motor. A 20 amp, designated braker must be supplied for 110V
	Hydraulic oil level low	When lift is raised as far as possible, oil level should be 3/4" from bottom of tank. When lift is down, 3/4" from top
	Lift has reached its upper limit	Upper limit switch may need to be adjusted
	Motor may be "single phasing"	If motor hums but does not turn, check motor wiring and line fuses.
	Motor voltage too low	Supply voltage should be +/- 10% of the rating at the motor terminals.
	Tank vent plugged	If supplied, remove solid plug from tank, insert vent plug.
	Suction filter clogged	Clean suction filter as described in periodic maintenance
	Vacuum leak in suction line	Check all fittings in suction line
	Down valve may be energized	Check wiring to down valve, and solenoid in the valve
	Missing coupling	Check to insure the coupling has been installed between the pump and motor
The lift fails to hold	Down valve may be leaking	Remove down valve and inspect for debris which may be preventing it from closing.
	Down valve may be energized	Check the solenoid in the valve with a volt meter.
	Cylinder may be leaking	Check for oil spillage.
Lift will not lower	Down valve may not be energized	Check the solenoid in the valve with a volt meter
Lift raises too slowly	Voltage may be low	Check voltage at motor to ensure proper voltage is being supplied
	Foreign material clogging suction filter, breather cap or pressure line	Remove necessary components and clean
	Pump may be overheating due to insufficient oil	Check oil level and oil viscosity
Lift lowers too slowly	Down valve may not be fully open or stuck closed	Remove down valve and clean

Ordering Replacement Parts

Southworth has carefully chosen the components in your unit to be the best available for the purpose. Replacement parts should be identical to the original equipment. Southworth will not be responsible for equipment failures resulting from the use of incorrect replacement parts or from unauthorized modifications to the machine.

Southworth can supply all replacement parts for your Southworth lift. With your order, please include the model number and the serial number of the unit. You will find these numbers on the name plate.

To order replacement parts, please call the Parts Department at (207) 878-0700. Parts are shipped subject to the following terms:

- FOB factory.
- Returns only with the approval of our parts department.
- Payment net 30 days (except parts covered by warranty).
- Freight collect (except parts covered by warranty).

Parts replaced under warranty are on a “charge-credit” basis. We will invoice you when we ship the replacement part, then credit you when you return the assumed substandard part.

Parts Department
Southworth Products Corp
P.O. Box 1380
Portland, ME 04104-1380
Telephone: (207) 878-0700
FAX: (207) 797-4734
RepairParts@SouthworthProducts.com

2 YEAR WARRANTY

Southworth Products Corp warrants this product to be free from defects in material or workmanship for a period of **two (2) years** of single shift usage from date of shipment, providing claim is made in writing within that time period. This warranty shall not cover modified designs for special applications, failure or defective operation caused by misuse, misapplication, negligence or accident, exceeding recommended capacities, failure to perform required maintenance or altering or repairing, unless alteration is authorized by Southworth Products Corp. Except as set forth herein, there are no other warranties, express or implied, including the warranties of merchantability and fitness for a particular purpose, all of which are hereby excluded.

Southworth Products Corp makes no warranty or representation with respect to the compliance of any product with state or local safety or product standard codes, and any failure to comply with such codes shall not be considered a defect of material or workmanship under this warranty. Southworth Products Corp shall not be liable for any direct or consequential damages arising out of such noncompliance.

Southworth Products Corp's obligation under this warranty is limited to the replacement or repair of defective components at its factory or another location at Southworth Products Corp's discretion. This is buyer's sole remedy. Except as stated herein, Southworth Products Corp will not be liable for any loss, injury or damage to persons or property, nor for direct, indirect, or consequential damage of any kind, resulting from failure or defective operation of said product.

This warranty may be altered only in writing by Southworth Products Corp, Portland, Maine.

SOUTHWORTH

SOUTHWORTH PRODUCTS CORP
P.O. Box 1380, Portland, ME 04104-1380
Telephone: 800-743-1000 • 207-878-0700
Fax: 207-797-4734
www.SouthworthProducts.com

SOUTHWORTH

making work faster, safer, and easier

Southworth is the world class supplier of products designed to improve productivity and enhance safety. Our staff has over 400 years of engineering experience. If one of our standard products does not meet your needs, our engineers can custom design equipment specifically suited to your material handling application.



Spring PalletPal Load Leveler



Lift with Flush Mount Turntable



Portable Container Tilters



Dock Lifts



Roll on Level Loaders



Portable Lifts



Stretchwrapping



Positioning

Floor to Mezzanine Lifts



Pallet Rotators



For more information, contact Southworth Products

Telephone (800) 743-1000 Fax (207) 797-4734

Email: salesinfo@SouthworthProducts.com