

Owner's Manual

ZLS Series

Floor Height Lift Tables

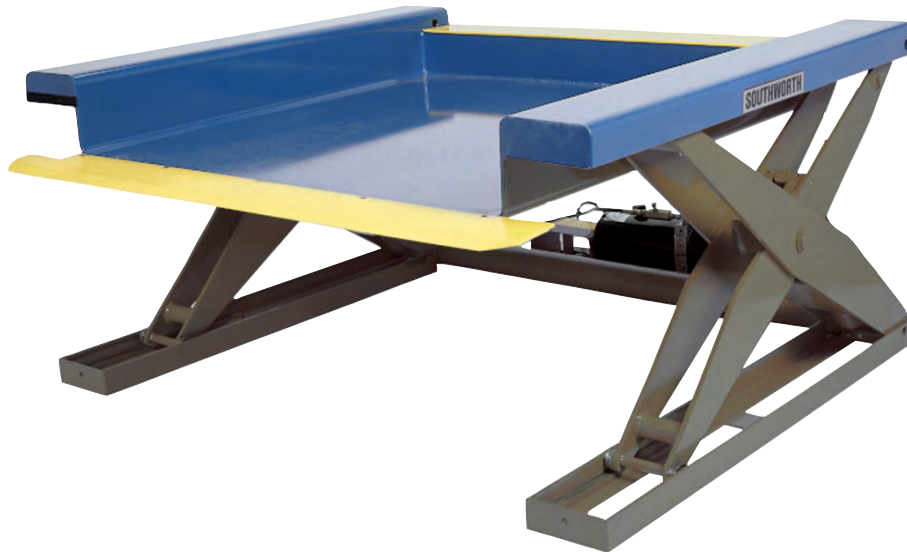

Model # _____

Serial # _____

SOUTHWORTH

Southworth Products Corp

P.O. Box 1380/Portland, Maine 04104-1380

Telephone 800/743-1000 or 207/878-0700 Fax 207/797-4734

www.southworthproducts.com

service@southworthproducts.com

October 2012

Please note: This manual was current at the time of printing.
To obtain the latest, most updated version, please contact Southworth's Customer Service Department or go to our website:
www.SouthworthProducts.com, under Parts & Service
you will find a complete list of current
owner's manuals to print.

Contents

INTRODUCTION4
 RESPONSIBILITY OF OWNERS AND USERS5
 SAFE SERVICING OF THE LIFT6
 SAFETY7
 INSTALLATION INSTRUCTIONS7
 Preparation7
 Positioning the Lift8
 Hydraulic Connections.....8
 Hydraulic Oil Specifications8
 Electrical Connections9
 Testing9
 OPERATOR INSTRUCTIONS 10
 Safety Label Compliance.....10
 Labels and Precautionary Markings 11
 Operating Procedures and Precautions 12
 MAINTENANCE 14
 Hazards 14
 Routine Periodic Maintenance 14
 Repacking the Cylinders 15
 Replacing the Rollers 15
 Troubleshooting Check List 16
 ORDERING REPLACEMENT PARTS20
 WARRANTY STATEMENT Back Cover

List of Figures

Fig. 1 Mount the Lift Securely - Safety Chocks7
 Fig. 2 Mount the Lift Securely - Add Lag Blocks.....7
 Fig. 3 Warning Labels 11
 Fig. 4 Center the Load 12
 Fig. 5 Secure the Load 12
 Fig. 6 Pinch Points 13
 Fig. 7 Contractor Box Connections 18
 Fig. 8 Parts Illustration — Front End of Lift 19
 Fig. 9 Parts Illustration — Rear End of Lift 19
 Fig. 10 Parts Illustration — Pump and Motor 19

INTRODUCTION

Southworth's "ZLS" Series includes Southworth's floor height lift units. The lift table on each unit may be lowered to floor height. This allows the operator to move loads on and off with only a hand pallet truck. The "ZLS" series includes three models: Model ZLS2 has a lift capacity of 2000 lb. (900 kg.) and a vertical travel of 35" (88.9 cm). The ZLS24 can lift 4000 lb. (1800 kg.) with a travel of 35" (88.9 cm). Model ZLS6 can lift 6000 lb. (2700 kg.) with a travel of 34" (86.3 cm.).

This manual contains information to help you to learn about the safe and proper installation, use, and upkeep of a "ZLS" Series lift table. Please be sure that this manual is available to anyone who works with the lift table. Be sure that everyone who uses the lift has read the manual.

In the interest of safety, please read all of this manual carefully, and be familiar with its contents before you install, use, or service the "ZLS" Series. If you have any questions about any of the instructions in this manual, please contact your dealer or Southworth Products Corporation.

Southworth's product warranty is shown on the back cover of this manual. This instruction manual is **not intended to be or to create any other warranty, express or implied, including any implied warranty of merchantability or fitness for a particular purpose, all of which are hereby expressly excluded.**

As set forth more specifically in the product warranty, Southworth's obligation under that warranty is **limited** to the repair or replacement of defective components, which shall be the buyer's **sole remedy**, and Southworth shall not be liable for any loss, injury, or damage to persons or property, nor for any direct, indirect, or consequential damage of any kind resulting from the "ZLS" Series table.

Responsibility of Owners and Users

Inspection and Maintenance

The device shall be inspected and maintained in proper working order in accordance with Southworth's owner's manual.

Removal from Service

Any device not in safe operating condition such as, but not limited to, excessive leakage, missing rollers, pins, or fasteners, any bent or cracked structural members, cut or frayed electric, hydraulic, or pneumatic lines, damaged or malfunctioning controls or safety devices, etc. shall be removed from service until it is repaired to the original manufacturer's standards.

Deflection

It is the responsibility of the user/purchaser to advise the manufacturer where deflection may be critical to the application.

Repairs

All repairs shall be made by qualified personnel in conformance with Southworth's instructions.

Operators

Only trained personnel and authorized personnel shall be permitted to operate the lift.

Before Operation

Before using the device, the operator shall have:

- Read and/or had explained, and understood, the manufacturer's operating instructions and safety rules.
- Inspected the device for proper operation and condition. Any suspect item shall be carefully examined and a determination made by a qualified person as to whether it constitutes a hazard. All items not in conformance with Southworth's specification shall be corrected before further use of the equipment.

During Operation

The device shall only be used in accordance with this owner's manual.

- Do not overload.
- Ensure that all safety devices are operational and in place.

Modifications or Alterations

Modifications or alterations to any Southworth industrial positioning equipment shall be made only with written permission from Southworth.

Safe Servicing of the Lift

Figure 1 shows the only safe way to work under the table top of the “ZLS” Series unit. In this manual, we will refer you to this procedure many times. **In the interest of safety, please follow all of these steps whenever you work under the table top:**

- Remove the load from the table top.
- Raise the table top to the full-up position.
- Place the supplied maintenance devices in the base rails as shown in Fig. 1. This will keep the legs from moving, and prevent the table top from dropping suddenly.

WARNING!

Both the maintenance devices must hold the lift table in the full-up position! A partly-raised lift may apply too much leverage against the base frame. This can cause the machine to fail, and this can cause severe personal injury to a worker.

- Lower the table a bit so the movable legs are resting against the maintenance devices. This will release the pressure in the hydraulic system and hold the maintenance devices in place. If you do not do this, pressure may remain in the hydraulic system. If this pressure is released suddenly, you may be hurt, or the lift may be damaged.
- While you are working on the lift, do not let anyone else use the controls.
- Finish working under the table top, then reverse the process to get the lift ready for operation.
- Go through all of these steps **every time** you must work under the table top. Do this even if you will only be under the table top for a moment!

SAFETY

Southworth is concerned about the safety of everyone who operates, maintains, repairs, or works near the “ZLS” Series unit. The lift table is a powerful machine with moving parts, and is **capable of causing personal injury if proper precautions are not taken.**

Therefore, throughout this manual, Southworth has identified certain hazards which may occur in the use of the lift table, and provided appropriate **instructions** or **precautions** that should be taken to avoid these hazards. In some cases, Southworth has also pointed out the **consequences** that may occur if Southworth’s instructions or precautions are not followed. Southworth uses the following system of identifying the severity of the hazards associated with its products:

“**DANGER**” - Immediate hazard which will result in severe personal injury or death.

“**WARNING**” - Hazard or unsafe practice which could result in severe personal injury or death.

“**CAUTION**” - Hazard or unsafe practice which could result in minor personal injury or property damage.

Please read and follow this instruction manual, including all safety instructions and precautions, carefully and completely.

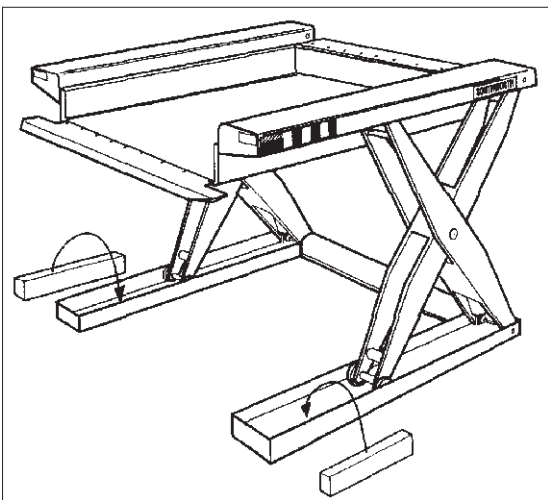

Fig. 1 – Mount the Lift Securely - Safety Checks

INSTALLATION INSTRUCTIONS

Preparation

1. Before you start to install the lift, check for local codes and ordinances which may apply. It is your responsibility to obtain any necessary permits.
2. **Read all of these installation instructions carefully. Be sure to read and understand all of the warnings!**
3. The lift should be placed indoors, or protected from the weather.

WARNING!

Protect the lift from rain or moisture. If the electrical parts in the power unit get wet, workers may be hurt by electrical shock. The electrical parts may fail if they are wet.

WARNING!

The electric motor can create sparks. Do not install the lift in an area where flammable gases may be present.

4. You will need these tools to install the lift:
 - A crane or lift truck that can lift the unit safely.
 - Shims and lag bolts.
 - A masonry drill and bit to drill the holes for the lag bolts.
 - Wrenches to fit the lag bolts and the nuts on the lifting eyes.
5. As you work on the lift, you will need two safety blocks to hold up the table top. Make up two blocks using pieces of 2” x 4” lumber which are 18” long.

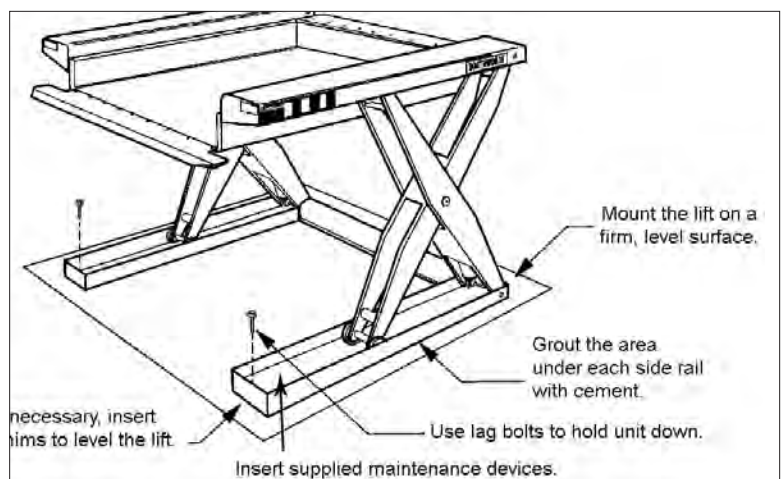

Fig. 2 – Mount the Lift Securely - Add Lag Bolts

Positioning the Lift

1. Remove the shipping material and unskid the lift. On the front of this manual, write down the model number, serial number, and date the lift is placed in service. You can find the model number and serial number on the name plate.
2. Move the lift into position, supporting the base of the lift. Use the lifting eyes at each end of the unit. Once the unit is in position, remove the shipping brace which connects the two base frames. This brace is held in place by the two eyebolts on the front of the unit. Remove these eyebolts, and also the eyebolts on the rear of the unit.
3. Install the lift as shown in Fig. 2. Bolt the lift to the floor using four lag bolts. These should run through the lag plates at each end of the base frames. Insert and tighten the lag bolts to secure the lift. Grout under the base rails to prevent vibration and distortion of the base frame.

CAUTION!

Do not try to move the lift by supporting the table top. One end of the table top is free.

WARNING!

If the lift is mounted on an unstable surface, it may tip over when it is in use. You may be hurt, and the lift and load may be damaged.

4. Attach the flexible safety lip to the front of the unit using the screws supplied (#10-24 x 3/8").
5. The standard unit has a 5 foot hose (1.2m) connecting the power unit to the lift. This can be extended to a maximum of 50 feet (12.7m).

Hydraulic Connections

(External Power Units Only – If Internal Power Unit, proceed to step 10.)

8. Install the power unit. Install the hydraulic line between the power unit and the lift as shown on the pit plan.
9. Blow out the hydraulic line with compressed air before connecting it to the power unit. Replace the solid plug on the hydraulic fluid tank with the vented plug supplied, then attach the vent line to the vented plug.

WARNING!

Be sure that the hydraulic line will not be pinched by the lift as it raises or lowers. If you allow the line to be pinched, the lift may not work properly. A hose may break, the lift table may drop suddenly, and someone may be hurt.

CAUTION!

It is very important to keep the hydraulic oil free of dirt, dust, metal chips, water, and other contamination. Most of the problems with hydraulic systems are caused by contamination in the oil. Be sure to flush all hydraulic lines before connecting remote power units.

CAUTION!

If you do not install the vented plug in the tank, the pump may be damaged.

Table 1 – Hydraulic Oil Specifications

If the lift will be used at normal ambient temperatures, Southworth supplies the unit with CONOCO 32 oil. This may be replaced by any other good quality oil with 150 SSU at 100° F and rust and oxidation inhibitors and anti-wear properties. If the lift will be used at ambient temperatures below 0°F, use aircraft hydraulic oil. Use Type 15 aircraft hydraulic oil.

The following are equivalent to CONOCO 32:

TYPE	MANUFACTURER
DTE 24	EXXON/MOBIL
NUTO H32	EXXON/MOBIL
AMOCO AW32	CHEVRON (AMOCO CO.)
CITGO AW32	CITGO

CAUTION!

It is very important to keep the hydraulic oil free of dirt, dust, metal chips, water, and other contamination. Most of the problems with hydraulic systems are caused by contamination in the oil.

Electrical Connections

DANGER!

The lift may use a power supply of up to 575 Volts AC. This voltage can kill you. Do not work with the electrical parts unless you are a qualified electrician.

1. The lift is supplied with a power cord which is 10' long (305 cm). You must provide a two-prong outlet within this distance from the lift. The circuit should be provided with a 20 amp circuit breaker or fuse.

WARNING!

To avoid fire danger, be sure to provide a circuit breaker or fuse.

2. The foot switch assembly is attached to the lift by a 10' cable (305 cm). Position the control box in a convenient location near the lift.
3. Check the level of the hydraulic fluid in the tank. When the lift is fully lowered, the oil should be 1/2" to 3/4" (13 to 19 mm) below the top of the tank. Add oil as necessary.

Testing

1. Clear the area around the lift. Remove any loose wires, lumber, or other materials which might get in the way of the lift as it raises or lowers.
2. Warn others to stay away from the lift. Operate the lift through its full range of travel. The lift should rise smoothly with a quiet humming sound, and lower smoothly and quietly. Raise and lower the lift a few times to check the clearances around the lift table.

WARNING!

As the lift table moves up and down, "pinch points" are created at the places shown in Fig. 5. If you are standing too close to the lift when it is moving, your arm or leg may be caught in the moving parts, and you may be hurt. Stay away from the pinch points when the lift is moving.

3. If the lift is lowering too quickly or too slowly, you can change the "down speed" by adjusting the flow control.

If you want the table top to lower more slowly, turn the control clockwise up to 1/4 turn at a time. If you want the table top to lower more quickly, turn the control counterclockwise up to 1/4 turn. Don't move the control more than 1/4 turn at a time.

4. Test the lift with the rated load. If the lift does not rise, and you hear a loud squealing noise, the pressure relief valve is operating. Contact Southworth for instructions.

WARNING!

When adjusting the flow control, always raise the lift table and insert the maintenance devices, as shown in Fig. 1. Do not try to adjust the flow control while pressing the "down" button. If you try this, the lift table may drop suddenly, and you may be hurt.

5. As a final step, clean up all spilled hydraulic fluid. Spilled hydraulic oil is slippery, and may present a fire hazard. If you clean up any spilled fluid, you will be able to tell right away if the lift begins to leak.

OPERATOR INSTRUCTIONS

SAFETY LABEL COMPLIANCE

To aid in understanding the concept and the importance of the symbol and signal word, the following has been excerpted from ANSI Z535.4.

4.10 Safety Alert Symbols

A symbol which indicates a potential personal injury hazard. It is composed of an equilateral triangle surrounding an exclamation mark. The safety alert symbol shall not be used to alert persons to property-damage-only accidents.



For use with DANGER signal word
(Red Background)



For use with WARNING signal word
(Orange Background)



For use with CAUTION signal word
(Yellow Background)

4.1 Signal Words

The meaning of different signal words as defined by ANSI Z535.6 and Z535.4 standards may be provided in collateral materials. The following artwork may be used for this purpose.



(Red Background)

DANGER indicates a hazardous situation which, if not avoided, will result in death or serious injury.



(Orange Background)

WARNING indicates a hazardous situation which, if not avoided, could result in death or serious injury.



(Yellow Background)

CAUTION, used with the safety alert symbol, indicates a hazardous situation which, if not avoided, could result in minor or moderate injury.



(Blue Background)

NOTICE is used to address practices not related to personal injury.

Fig. 3 – Warning Labels

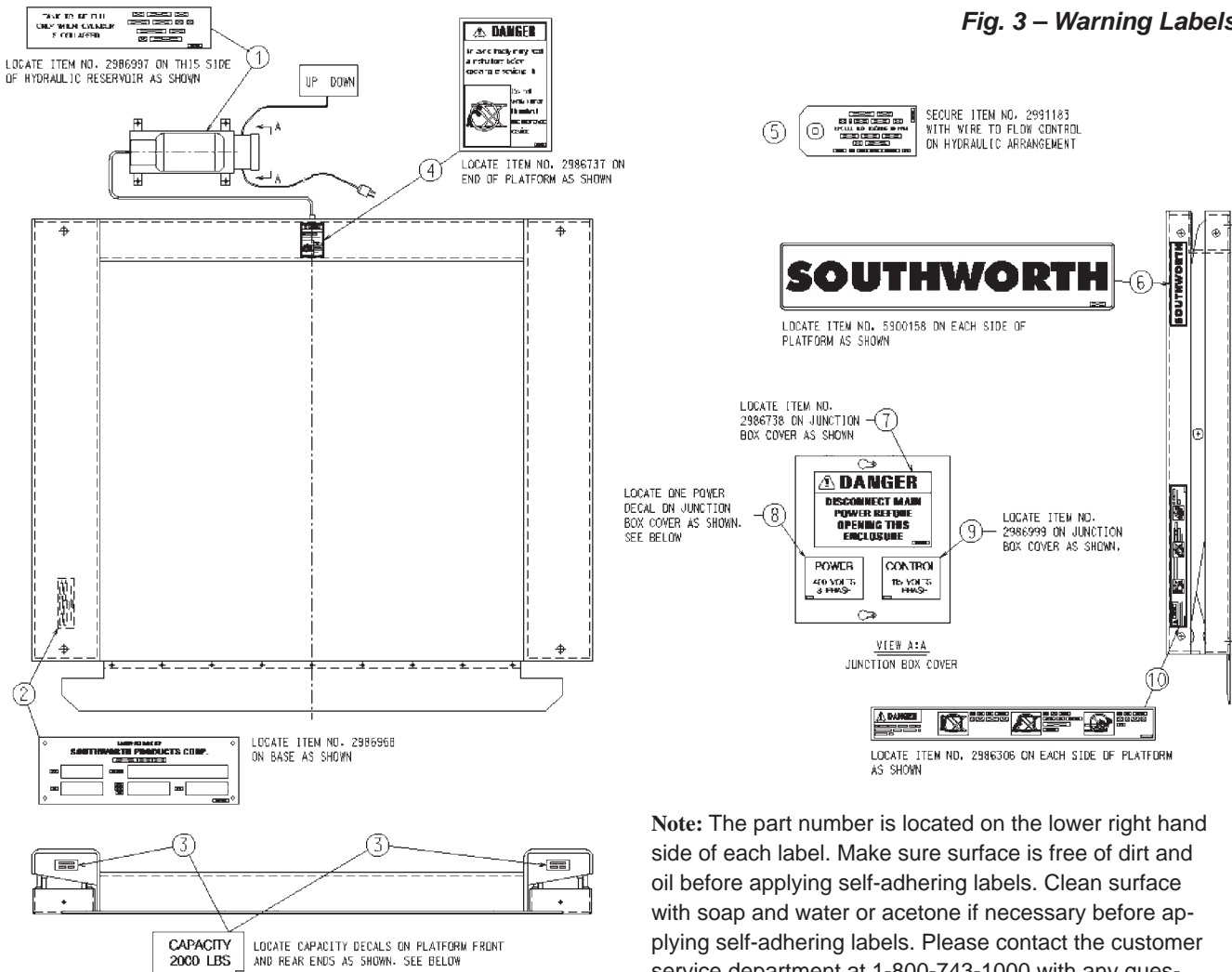

Note: The part number is located on the lower right hand side of each label. Make sure surface is free of dirt and oil before applying self-adhering labels. Clean surface with soap and water or acetone if necessary before applying self-adhering labels. Please contact the customer service department at 1-800-743-1000 with any questions.

ITEM	PART#	LOCATION
1	2986997	Locate on side of hydraulic reservoir as shown.
2	2986968	Locate on base as shown.
3	2998427 2998426	2000# Capacity Locate capacity decal specific to machine 4000# Capacity on platform front and rear as shown.
4	2986737	Locate on end of platform as shown.
5	2991183	Secure with wire to flow control on hydraulic arrangement. Hydraulic arrangement not shown.
6	5900158	Locate on each side of platform as shown.
7	2986738	Locate on junction box cover as shown.
8	2987000 2987001 2987002 2987003	115/1/60 208/3/60 230/3/60 460/3/60 Locate power decal specific to machine on junction box cover as shown.
9	2986999	Locate on junction box cover as shown.
10	2986306	Locate on each side of platform as shown.

OPERATING PROCEDURE AND PRECAUTIONS

1. Before operating the lift, please read this whole section. If your lift has any optional modifications or accessories, information on these will be included at the end of the manual.

DANGER!

The lift may use a power supply of up to 440 Volts AC. This voltage can kill. Do not work with the electrical parts unless you are a qualified electrician!

2. Load the lift correctly.
 - Be sure that the load weighs no more than the maximum rated for the lift.

ZLS2	2000 lb. (900 kg.)
ZLS4	4000 lb. (1800 kg.)
ZLS6	6000 lb. (2700 kg.)

WARNING!

Do not try to lift a load that exceeds the maximum rating. If you try this, the lift may fail suddenly. Someone may be hurt, and the lift and load may be damaged.

- Place the load in the center of the lift table, as shown in Fig. 3.
 - Do not try to load the lift while the lift table is moving.
 - If you are lifting pipes or other objects which may be able to roll or move, fasten them down, or hold them in place with blocks as shown in Fig. 4.
3. **Be sure all workers are clear of the lift.** Remove any lumber or other material that may fall onto the lift.

WARNING!

Do not use the unit to lift people! This lift is not designed for this purpose. It does not have the special safety features required for this type of service. If the lift drops suddenly, anyone riding on the lift may be hurt.

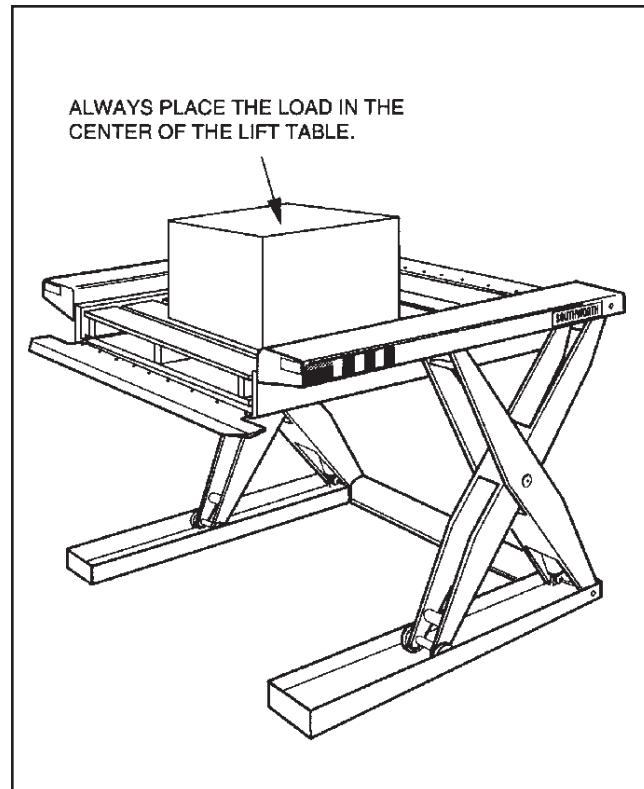

Fig. 4 – Center the Load

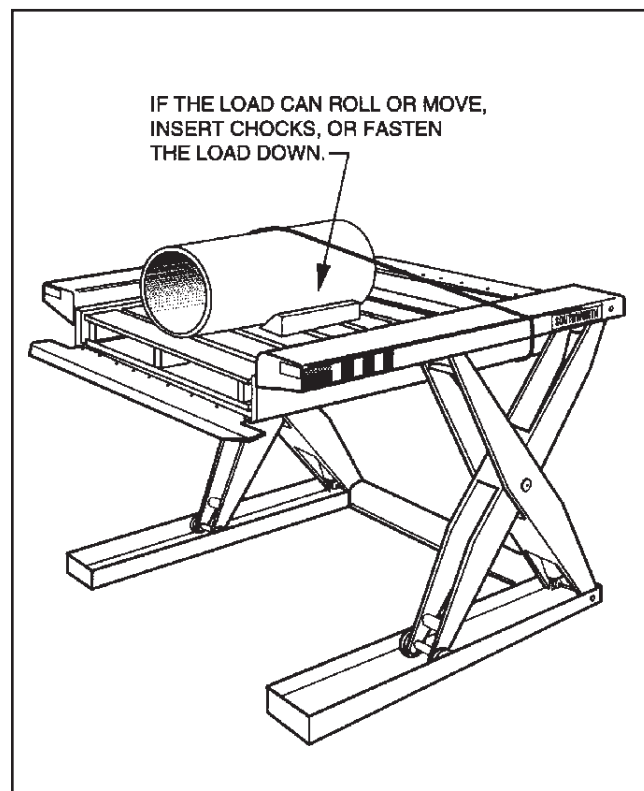

Fig. 5 – Secure the Load

WARNING!

As the lift table moves up and down, “pinch points” are created as shown in Fig. 5. Stay away from these pinch points! Part of your body or clothing may become caught, and you may be hurt.

- Operate the lift. Press and hold the “up” button to raise the lift, and “down” to lower it. If the lift does not operate right away, disengage the control and call a qualified maintenance worker.

WARNING!

If you hear a squealing noise from the pump, the pressure relief valve is operating. Do not continue to use the lift! The pump will overheat very quickly, and may be permanently damaged. The relief valve is included to protect the machine operators – do not change the relief pressure setting.

- When the table reaches the end of its travel, you will hear the pump motor speed up. Release the control button to stop the lift. It is better to stop the lift just a moment before the table reaches the end of its travel. This will reduce wear on the pump and motor.

WARNING!

The warning labels on the lift are there for your safety. If you find that the labels are worn or missing, or have been painted over, ask Maintenance to replace the labels before you use the lift. The labels are shown in Fig. 6.

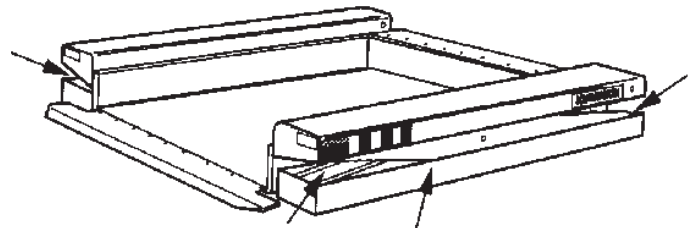
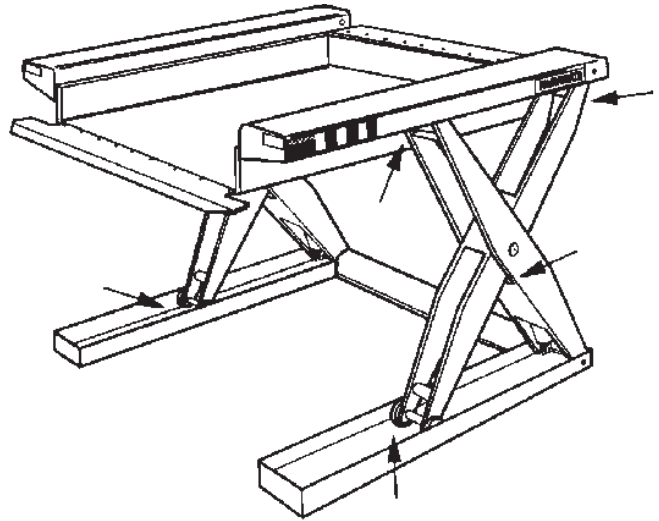

Fig. 6 – Pinch Points

MAINTENANCE

All servicing should be done by qualified personnel. Qualified personnel should be able to read and understand wiring and hydraulic diagrams. They should be able to troubleshoot live electrical circuits safely and in accordance with accepted practice. For safety's sake, if in doubt, please contact your dealer or Southworth Products Corporation Customer Service Department at (207) 878-0700 or (800) 743-1000.

Before servicing the lift, please read and understand this section of the manual. Please read the section on "Operating Instructions." If your lift has any optional modifications and accessories, the information on these will be inserted at the end of the manual.

Hazards

There are several hazards you should be aware of as you service the lift:

DANGER!

The lift may use a power supply of up to 400 Volts AC. This voltage can kill. **Do not work with the electrical parts unless you are a qualified electrician!**

WARNINGS!

- As the lift moves up and down, "pinch points" are formed as shown in Fig. 5. **Keep hands, feet, and loose clothing away from these pinch points.** If your hand or arm or a part of your clothing is caught, you may be hurt.
- A falling lift can cause severe personal injury. Before working under the table top, **raise the lift and insert the maintenance devices, as shown in Fig. 1.** Do this every time you work under the table top!

WARNINGS!

- **Do not change the setting on the relief valve.** If you do change the setting, this may cause a hydraulic part to fail. The lift may drop suddenly. Someone may be hurt, and the lift and the load may be damaged. The hydraulic parts in the lift are designed to handle a certain amount of pressure. The relief valve is set to relieve this pressure before it becomes too great. The relief valve has been included for the protection of all of the workers who use the lift.
- If the hydraulic fluid is released when it is under pressure, it can cause personal injury. This can cause the lift to drop suddenly. Before you open any part of the hydraulic system, **be sure to release the hydraulic pressure.** One way of doing this is to lower the table top completely.

If you must work with the cylinders, or work under the table, use a different procedure. Raise the table top, insert the maintenance devices and lower the lift onto the maintenance devices. This will take the load off the hydraulic system.

- The warning labels on the lift are there for the safety of the operators. See Figs. 6. If the labels are worn or missing, or have been painted over, **replace them** before releasing the lift for operation.

Routine Periodic Maintenance

Every month:

- Visually inspect the leg rollers, center pivot pins and bushings, cylinder clevis pin and bushings, and the leg hinge pins and bushings for signs of wear. If the center pivot pins and bushings need repair, contact Southworth for instructions.

WARNING!

If you are going to repair the center pivot pins and bushings, you must support the lift table in a special way. Each set of leg plates, on both sides of the unit, must be clamped together firmly, using large C-clamps. You cannot use the maintenance devices shown in Fig. 1 with the pivot pins removed. They will not support the table top correctly. If you do not support the table top correctly, the top may drop suddenly when you remove the pivot pins. **Please contact Southworth for instructions.**

- Apply oil or WD-40 to the parts listed in the last step. Although the bearings are "lifetime lubricated" their performance may be extended by additional lubrication from time to time.
- Check the level and appearance of the hydraulic fluid. When the lift table is fully lowered, the oil should be 1/2" to 3/4" (13 to 19 mm.) from the top of the tank. Add oil as necessary. Change the oil if it has darkened, or feels gritty or sticky.

CAUTION!

It is important to use hydraulic fluid with the correct grade and properties. See Table 1, page 9, for the hydraulic oil specifications.

Every six months or 500 hours of operation, whichever comes first:

- Raise the lift table and insert the maintenance devices, as shown in Fig. 1.

- Check all of the hydraulic fittings and hoses, and tighten the connections as necessary. Sometimes the fittings can be worked loose by the vibrations from the power unit.

WARNING!

If a hydraulic fitting becomes loose, or if a hydraulic hose breaks, the hydraulic fluid may escape from the system under pressure. If the lift table is elevated when this happens, it can drop quickly. Someone may be hurt, or the lift or load may be damaged. Be sure all hydraulic fittings are tight.

- The clear plastic vent line and the surface of the cylinder rod should be free of hydraulic fluid. If you find much fluid in either place, the cylinder seals may be leaking. (It is also possible the tank may be overfilled.) Contact the Southworth Parts Department for instructions on repacking the cylinder.
- Disassemble the down valve. Blow the valve plunger clean with compressed air. Reassemble and reinstall the valve.
- Drain and discard the hydraulic fluid. The suction filter is in the tank, at the point where the suction line runs out to the pump. Unscrew the hydraulic line, then remove the filter. Blow the filter clean with compressed air. Reinstall the filter in the tank and reassemble the hydraulic line.
- Refill the tank with new hydraulic fluid.

CAUTION!

If you continue to use fluid after it has “worn out,” the moving parts in the system will wear more quickly.

- Be sure all of the warning labels are in position and legible. The labels are shown in Figure 6. **The warning labels are intended to protect your workers.** If the labels are missing, or if they have been painted over, replace them.

Repacking the Cylinders

The lifts in the “ZLS” Series may use several different types of cylinders. To order a repacking kit and receive repacking instructions, please call the Southworth Parts Department at (207) 878-0700 or (800) 743-1000. When ordering, specify the model number and serial number of the lift.

Replacing the Leg Rollers

For instructions, please call the Southworth Parts Department at (207) 878-0700 or (800) 743-1000. When ordering replacement parts, please specify the model number and serial number of the lift.

TROUBLESHOOTING

PROBLEM	POSSIBLE CAUSE	CHECK THIS
Lift will not raise	Weight of load too heavy	Check the actual weight of the load
	Motor not running	Check the main disconnect switch, fuses, and wiring to the motor. A 20 amp, designated braker must be supplied for 110V
	Hydraulic oil level low	When lift is raised as far as possible, oil level should be 3/4" from bottom of tank. When lift is down, 3/4" from top
	Lift has reached its upper limit	Upper limit switch may need to be adjusted
	Motor may be "single phasing"	If motor hums but does not turn, check motor wiring and line fuses.
	Motor voltage too low	Supply voltage should be +/- 10% of the rating at the motor terminals.
	Tank vent plugged	If supplied, remove solid plug from tank, insert vent plug.
	Suction filter clogged	Clean suction filter as described in periodic maintenance
	Vacuum leak in suction line	Check all fittings in suction line
	Down valve may be energized	Check wiring to down valve, and solenoid in the valve
	Missing coupling	Check to insure the coupling has been installed between the pump and motor
The lift fails to hold	Down valve may be leaking	Remove down valve and inspect for debris which may be preventing it from closing.
	Down valve may be energized	Check the solenoid in the valve with a volt meter.
	Cylinder may be leaking	Check for oil in cylinder in the vent line.
Lift will not lower	Down valve may be de-energized	Check the solenoid in the valve with a volt meter
	Flow control needs adjustment	Adjust flow control as needed
Lift raises too slowly	Voltage may be low	Check voltage at motor to ensure proper voltage is being supplied
	Foreign material clogging suction filter, breather cap or pressure line	Remove necessary components and clean
	Pump may be overheating due to insufficient oil	Check oil level and oil viscosity
Lift lowers too slowly	Down valve may not be fully open or stuck closed	Remove down valve and clean
	Flow control may need adjustment	Adjust flow control as needed

TROUBLESHOOTING WARNINGS

All servicing should be done by qualified personnel. Qualified personnel should be able to read and understand wiring and hydraulic diagrams. They should be able to troubleshoot live electrical circuits safely and in accordance with accepted practice. **For safety's sake**, if in doubt, please contact your dealer or Southworth Products Corp. Before servicing the lift, **read and understand this entire section and the section entitled "Operating Instructions."**

WARNING!

Before working underneath the lift, always raise the lift and insert the maintenance devices, as shown in Figure 1. Failure to do so may result in damage to the lift and severe personal injury!

If the lift will not raise:

CAUTION!

Do not continue to hold the "up" button for more than 2 or 3 seconds. You may damage the pump.

WARNING!

Do not change the relief valve setting. This valve has been included for the protection of workers who install, use, or service the lift. If it is ever necessary to repair or reset the valve, contact Southworth Products Corp. for instructions.

WARNING!

Do not disconnect the up limit switch. Instead, loosen the adjusting screw, and change the position of the arm. If you do disconnect the switch, when the lift platform moves up, it may not stop at the correct point. If the platform rises above the normal stopping point, the frame of the unit may be damaged. People working nearby may be hurt.

CAUTION!

If cavitation is allowed to continue, the pump may be damaged, and may have to be replaced.

If the lift elevates, but fails to hold a load:

WARNING!

Failure to insert the maintenance devices may result in damage to the lift and severe personal injury!

If the lift fails to lower:

WARNING!

Failure to insert the maintenance devices may result in damage to the lift and severe personal injury!

DANGER!

Do not try to adjust the flow control while pressing the "down" button. If you try this, the lift table may drop suddenly, and you may be hurt.

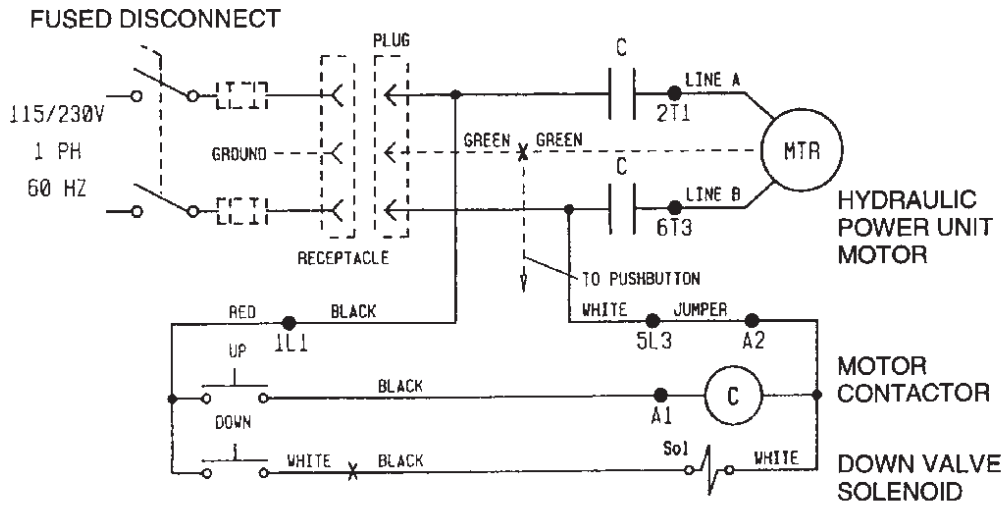

● - INDICATES TERMINAL ON THE CONTACTOR

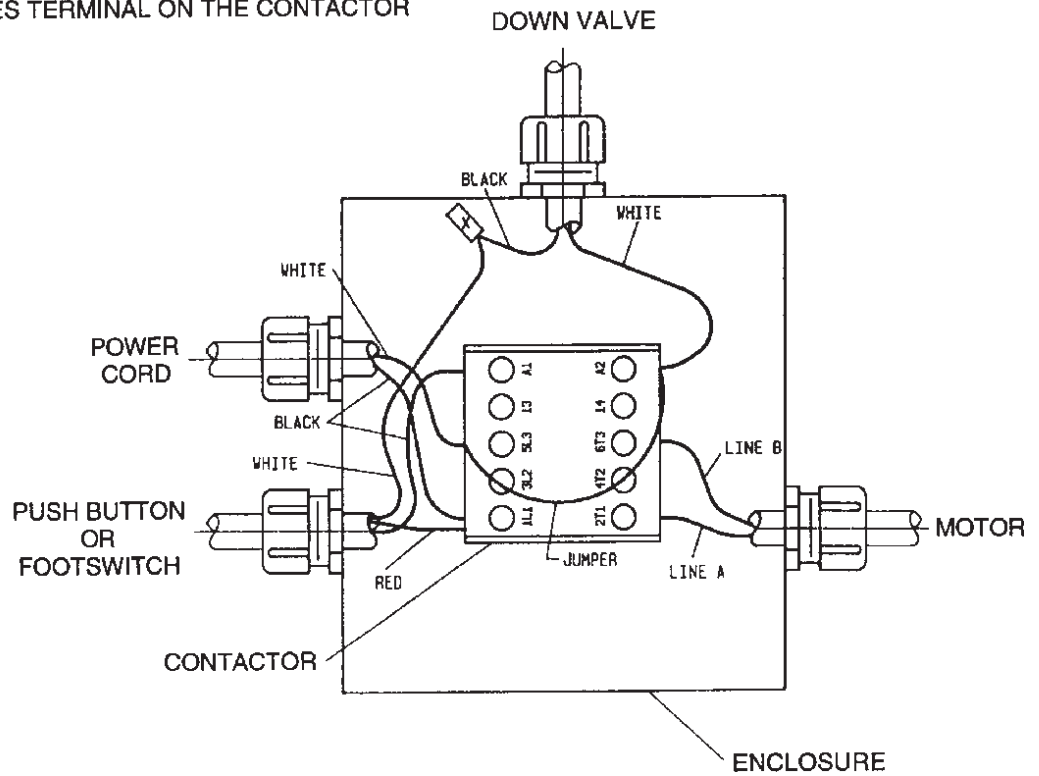

Fig. 7 – Contractor box connections

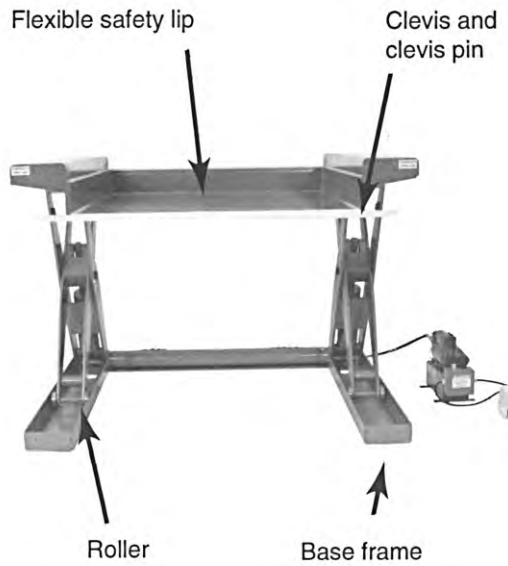
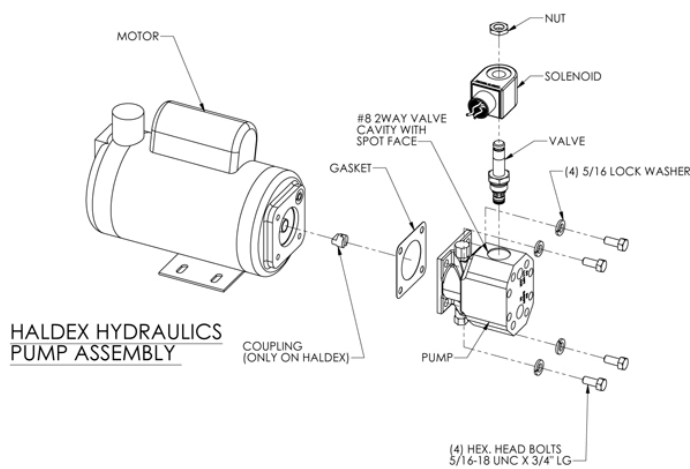

Fig. 8 – Parts Illustration — Front End of Lift

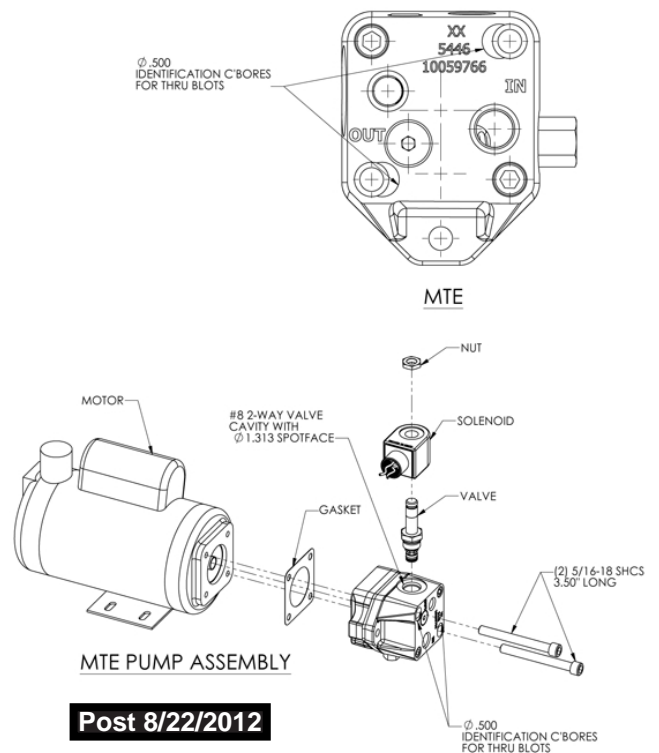

Fig. 9 – Parts Illustration — Rear End of Lift



Pre 8/22/2012

Fig. 10 – Parts Illustration — Pump and Motor



Post 8/22/2012

Ordering Replacement Parts

Southworth has carefully chosen the components in your lift to be the best available for the purpose. Replacement parts should be identical to the original equipment. **Southworth will not be responsible for equipment failures resulting from the use of incorrect replacement parts or from unauthorized modifications of the machine.**

Southworth will gladly supply you with replacement parts for your Southworth lift. Key parts are identified in Figures 8 through 15. With your order, please include the model number and the serial number of the lift. You can find these numbers on the name plate, which is located on the crossbar at the base of the cylinder(s). When you are ordering parts for a cylinder, also include the cylinder number. This is stamped on the base of the cylinder housing.

To order replacement parts, please call the Parts Department.

Parts are shipped subject to the following terms:

- FOB factory
- Returns only with the approval of our parts department.
- Payment net 30 days (except parts covered by warranty).
- Freight collect (except parts covered by warranty).

Parts replaced under warranty are on a "charge-credit" basis. We will invoice you when we ship the replacement part, then credit you when you return the worn or damaged part.

Parts Department

Southworth Products Corp.

Telephone 207) 878-0700 or (800) 743-1000

FAX : (207) 797-4734

repairparts@SouthworthProducts.com

www.SouthworthProducts.com

2 YEAR WARRANTY

Southworth Products Corp warrants this product to be free from defects in material or workmanship for a period of *two (2) years* of single shift usage from date of shipment, providing claim is made in writing within that time period. This warranty shall not cover modified designs for special applications, failure or defective operation caused by misuse, misapplication, negligence or accident, exceeding recommended capacities, failure to perform required maintenance or altering or repairing, unless alteration is authorized by Southworth Products Corp. Except as set forth herein, there are no other warranties, express or implied, including the warranties of merchantability and fitness for a particular purpose, all of which are hereby excluded.

Southworth Products Corp makes no warranty or representation with respect to the compliance of any product with state or local safety or product standard codes, and any failure to comply with such codes shall not be considered a defect of material or workmanship under this warranty. Southworth Products Corp shall not be liable for any direct or consequential damages arising out of such noncompliance.

Southworth Products Corp's obligation under this warranty is limited to the replacement or repair of defective components at its factory or another location at Southworth Products Corp's discretion. This is buyer's sole remedy. Except as stated herein, Southworth Products Corp will not be liable for any loss, injury or damage to persons or property, nor for direct, indirect, or consequential damage of any kind, resulting from failure or defective operation of said product.

This warranty may be altered only in writing by Southworth Products Corp, Portland, Maine.

SOUTHWORTH

SOUTHWORTH PRODUCTS CORP
P.O. Box 1380, Portland, ME 04104-1380
Telephone: 800-743-1000 / 207-878-0700
Fax: 207-797-4734
www.SouthworthProducts.com

SOUTHWORTH

We'll Show You How

Southworth is the world class supplier of products designed to improve productivity and enhance safety. Our staff has over 400 years of engineering experience. If one of our standard products does not meet your needs, our engineers can custom design equipment specifically suited to your material handling application.



Spring PalletPal Load Leveler



Lift with Flush Mount Turntable



Portable Container Tilters



Dock Lifts



Roll on Level Loaders



Portable Lifts



Stretchwrapping



Positioning

Floor to Mezzanine Lifts



Pallet Rotators



For more information, contact Southworth Products
Telephone (800) 743-1000 Fax (207) 797-4734
Email: salesinfo@SouthworthProducts.com